

Anthropomorphic Stone Monoliths on the Islands of Oreor and Babeldaob, Republic of Belau (Palau), Micronesia

Jo Anne Van Tilburg¹

ABSTRACT

This paper presents aspects of archaeological fieldwork on the islands of Oreor (Koror) and Babeldaob (Babelthaup), Republic of Belau (Palau), Micronesia. The project goal was the documentation, analysis and typological classification of monolithic stone carvings possessing anthropomorphic features. Thirty-eight monoliths were documented, 28 of which are anthropomorphic. These are here fully described and classified into 4 types based upon morphology and formal characteristics. The resultant sculpture typology is then related to archaeological context, and some issues of statue function and meaning are preliminarily addressed through ethnographic data and comparative analysis.

INTRODUCTION

In 1987, I undertook 8 weeks of intensive field work in Belau (Fig. 1).² The purpose of the project was to collect data on the formal and stylistic characteristics of monolithic sculpture in archaeological contexts (Table 1). The perceived value of these data was to form 1 component of an in-process comparative study of Pacific anthropomorphic, monolithic stone sculpture that began on Easter Island in 1981 (cf. Van Tilburg 1986, 1987, 1988).

This project was designed to incorporate and elaborate upon the previous typological work begun by Hidikata ([Hijikata] 1956, 1973a, 1973b) and Osborne (1966, 1979). It was implemented within the established guidelines of the archaeological survey as conducted throughout the Republic by the Division of Cultural Affairs (Gumerman et al. 1981; Lucking 1984; Masse et al. 1984).

PREVIOUS INVESTIGATIONS

The 1st survey of villages in Belau was done by Kramer (1917–29) who also noted, sketched and collected ethnographic data on some carvings.³ The 1st organized survey of stone carvings

1. Rock Art Archive, Institute of Archaeology, University of California, Los Angeles, California 90024, USA.

2. There is a new consistency in spelling of Belauan when incorporated into English texts, but confusion still remains and the comments of Osborne (1966:9) are still pertinent. Names of islands, states and villages were spelled according to the *Palau Register of Historic Places Manual for Numbering System* (1980). These were checked with the state code list of the Micronesian Area Map Project, Micronesian Area Research Center, University of Guam.

For all other Belauan terms (nonplace names) I consulted the *Palauan-English Dictionary* (McManus et al. 1976). While I realize that not every reader will be pleased with the use of Belauan language terms in this paper, I have made an attempt to be both consistent and logical. Until clear and reasonable guidelines are established for English writers, this is the best that one can currently hope.

3. An unedited English partial translation of Kramer (1917–29) was reviewed in the Belau Museum library (n.d.[HRAF]). Citations are from 1 of these 2 sources, as indicated.

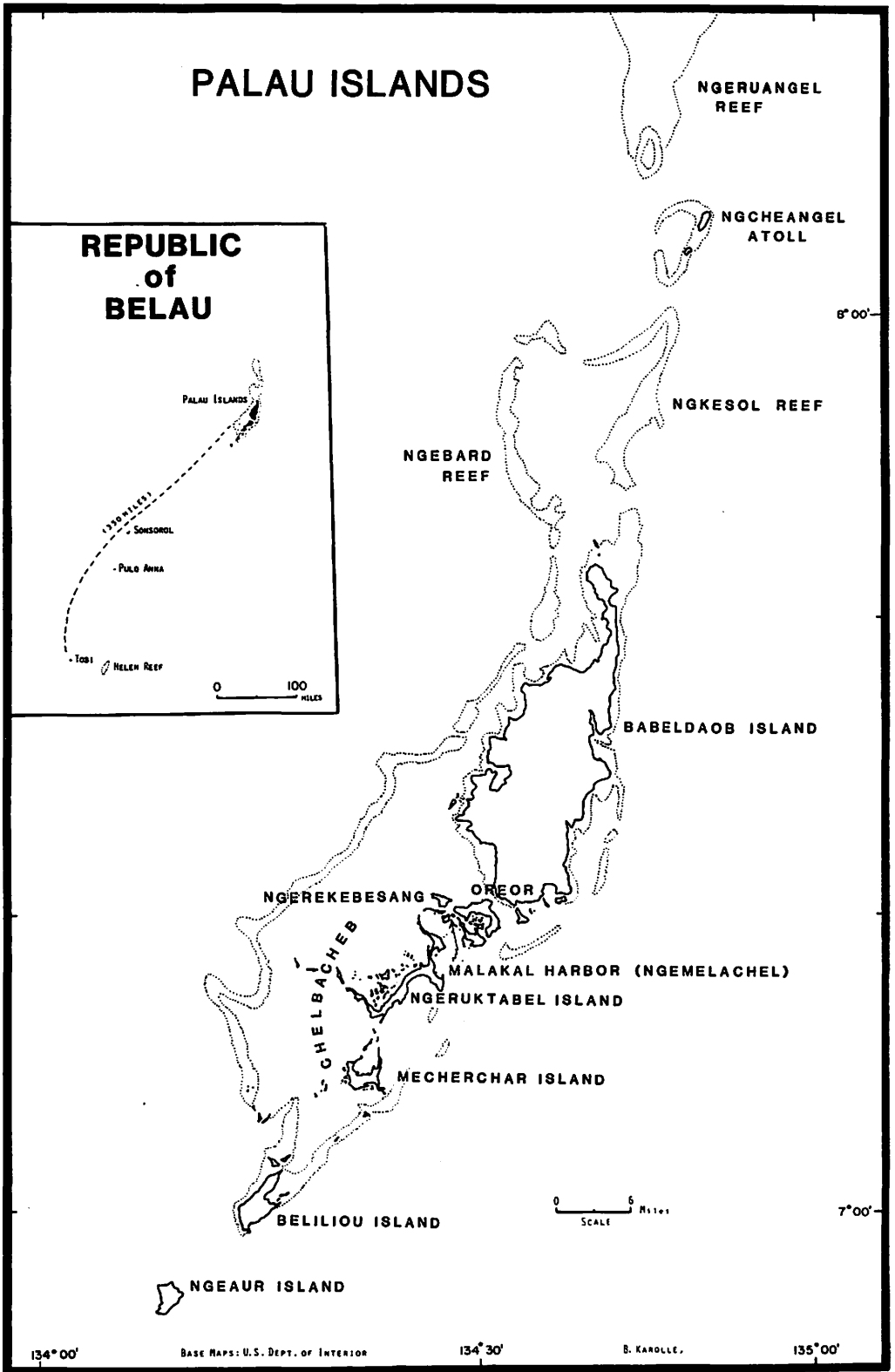

Fig. 1. Map of Belau from The Atlas of Micronesia. Courtesy Bruce G. Karolle.

Table 1. Belau Monolithic Sculpture

BELAU PLACE NAMES	PROJECT NUMBER (PN)	OSORNE NUMBER	DCA SURVEY NUMBER	CURRENT LOCATION CODE	FIGURE TYPE	POSITION CODE	TOTAL HEIGHT CM	CARVING TECHNIQUE CODE	MATERIAL CODE	ORIENTATION	STATUE NAME
Ngerbodol	01	K24	B:OR-3:6	1	D	3	85.4	1	5	N	
Imeong	02	B1	B:NM-3:1	9	B1	3	63.5	3	3	SE	"Ilong"
Iyobukel	03	K15	B:OR-4:1	1	A1	3	65	1	2	S	
Ngamid	04	K3b	B:OR-1:1	8	A2	3	138.5	2	2	N	"Dirrangerekesauol" "Mrs. Ngerekesauol"
Melekeek	05	B37	B:ME-4:2	5	A2	2	274	1	2	SE	"Chiuaiu" "Sleeper"
Melekeek	06	B37	B:ME-4:2	5	A3	3	293	3	2	E	"Odalechmelech" "God of the Village"
Melekeek	07	B37	B:ME-4:2	5	A1	3	195	1	2	E	"Obadebusech" "The Trumpeter"
Melekeek	08	B37	B:ME-4:2	5	A1	3	146	1	2	E	"Orerenges Chais" "Hears News"
Melekeek	09	B37	B:ME-4:2	5	A3	3	119	2	2	NE	"Mengachui" "Eats Hair"
Melekeek	10	B37	B:ME-3:1	5	B5	4	42.3	3	3		"Mengachui" "Eats Hair"
Ngial	11	B36	B:NI-1:2	5			34.4	3	6		"Tendokl" "Guardian Deity"
Ngerberuch	12	B9	B:IM-6:1	7	A1	3	79	1	1	E	
Imul	13		B:IM-1:1	2	A2	3	113	1	2	S	
Ngkekklau	14	B34	B:NA-1:1	2	B2	3	56	3	3	W	
Ngkekklau	15	B34	B:NA-1:1	2	B3	3	75	3	3	W	"Uchelkekklau" "God of the Village"
Ngkekklau	16	B34	B:NA-1:1	2	A1	3	40	2	1	W	"Chesuch" "Owl"
Ngetpang	17	B4	B:NT-2:1, f9	6	A1	3	84.5	1	2	W	"Chesuch" "Owl"
Ngetpang	18	B4	B:NT-2:1, f9	6	B4	3	58	3	3	W	"Mother Medechelbelau"
Bairulchau	19	B18a	B:NE-4:4	2	A3	3	149	2	2	N	
Bairulchau	20	B18b	B:NE-4:4	2	A3	3	143	2	2	W	
Bairulchau	21	B18c	B:NE-4:4	2	A3	3	162	2	2	S	
Bairulchau	22	B18d	B:NE-4:4	2	A3	3	174	2	2	E	
Bairulchau	23	B18e	B:NE-4:4	2	A3	3	131	2	2	E	
Bairulchau	24	B18f	B:NE-4:4	2	A3	3	177	2	2	S	
Ngardmau	25	B23	B:NR-2:1, f3	3	C1	3	82.5	3	3	W;E	"Beduk Liel"
Irrai	26	B29	B:IR-1:1	1	C2	3	55	3	3		"Medechelbelau" "Break Belau"
Imeong	27	B1	B:NM-3:1	9	B1	3	53	3	3	W	"Iechadrachululu" "Mr. Protection"
Ngerekngong	28			9	A1	3	103	1	2	NE	"Chesuch" "Owl"

was carried out pre-World War II by Hidikata ([Hijikata] 1956, 1973b), who covered a great deal of territory, sketched and briefly described a range of portable and monolithic stone sculpture and collected stories and legends associated with them.⁴ Unfortunately, at the time of Hidikata's survey, the Japanese administration seems to have been actively confiscating stone images in an effort to suppress what they considered undesirable religious practice, some of it associated with the *Modekengei* religion. Images were, as a consequence, frequently moved about, damaged or hidden. Hidikata's work, notwithstanding some problems in description, was a substantial salvage effort.

Osborne (1966, 1979) carried the study further as part of his extensive survey project. He established an initial classification of the recorded figures, distinguishing between "megaliths" only perfunctorily worked into anthropomorphic form; portable figures; standing stones with names and histories but lacking carved features, and what he called "Great Faces."

Gumerman et al. (1981), Carucci (1984), Lucking (1984), Parmentier (n.d., 1981, 1987) and Snyder (1983, 1985) all provide some observations on stone figures. No attempt has been made prior to the present study, however, to elaborate and clarify descriptions or to develop a flexible and comprehensive analysis of monolithic form and iconography.

PROJECT METHODOLOGY

Osborne (1966:475) provides a rationale for the study of Belauan art in archaeological contexts when he writes:

A most interesting and potentially rewarding aspect of the study of Palau prehistory revolves around the imperishable art work in stone and in pictographic remains. Relationships with megalithic art pieces elsewhere in the Pacific are not known to me. The stone work, large and small, is stylized and apparently similar to old carving in shell. Unless it can be shown to have derived from elsewhere, there is every reason to believe that there was a long period of local art development. The study of this development is another of the many intriguing problems that center around this small group of islands.

We utilized Osborne's (1966) archaeological report to select a range of monuments appropriate for documentation and located the sites with the assistance of the Division of Cultural Affairs, the Palau Community Action Agency (PCAA) and existing maps (Fig. 2). Aspects of the survey have been undertaken by various teams of scholars over a number of years since Osborne's original work, and by 1987 2 of the 16 states in the Republic had been intensively surveyed to a point where they might be considered nearly complete.

Artifacts surface collected, areas or features excavated or otherwise recorded during the survey have been classified into 3 categories: discrete portable objects (potsherds, chipped and ground stone); discrete nonportable features (platforms, statues, uprights); and nondiscrete, nonportable areas (terraces) (Gumerman et al. 1981). Stone statues or monuments are 1 of 10 elements that define Level 1, a "village settlement system" of a 2 level settlement system research model that has been developed (*ibid.*:17).

Two research foci related to the sculpture typology are embedded in the settlement system model. The 1st is the definition of specific contextual placement of individual monolithic sculpture types. The 2nd is to discern how, if at all, monolithic sculpture types relate to postulated regional centers of power.

This project, then, is separate from but clearly relevant to the settlement systems model. It is a surface survey concerned with the definition, description, placement, associations, possible

4. Hidikata (1973b) contains line drawings that are inferior in quality to originals published with a Japanese text (Hijikata 1958). Note variant spellings of the author's name.

**DOCUMENTED MONOLITHIC SCULPTURE SITES,
BABELDAOB ISLAND, BELAU**

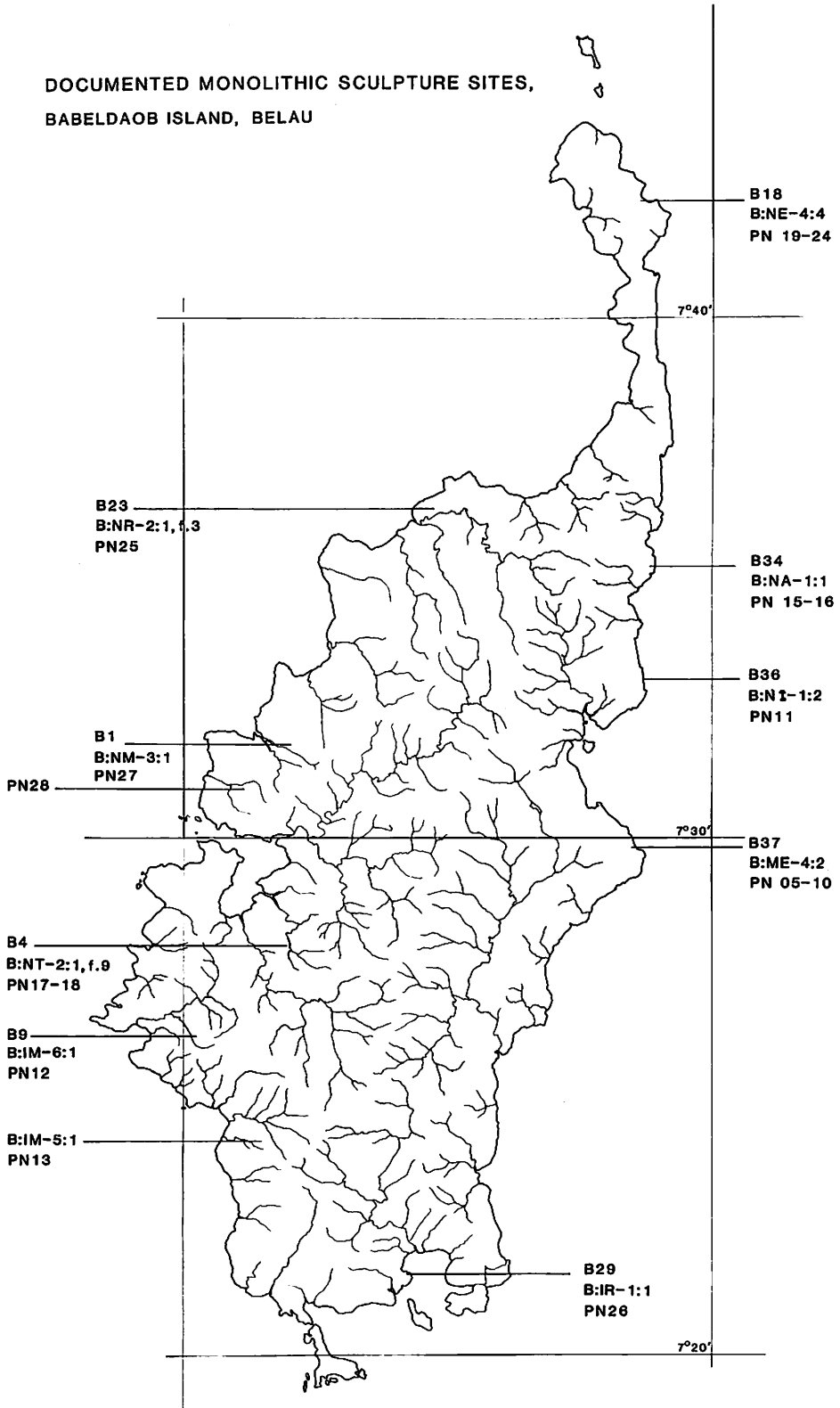

Fig. 2. Location of monolithic sculpture sites. Base Map, D. Osborne.

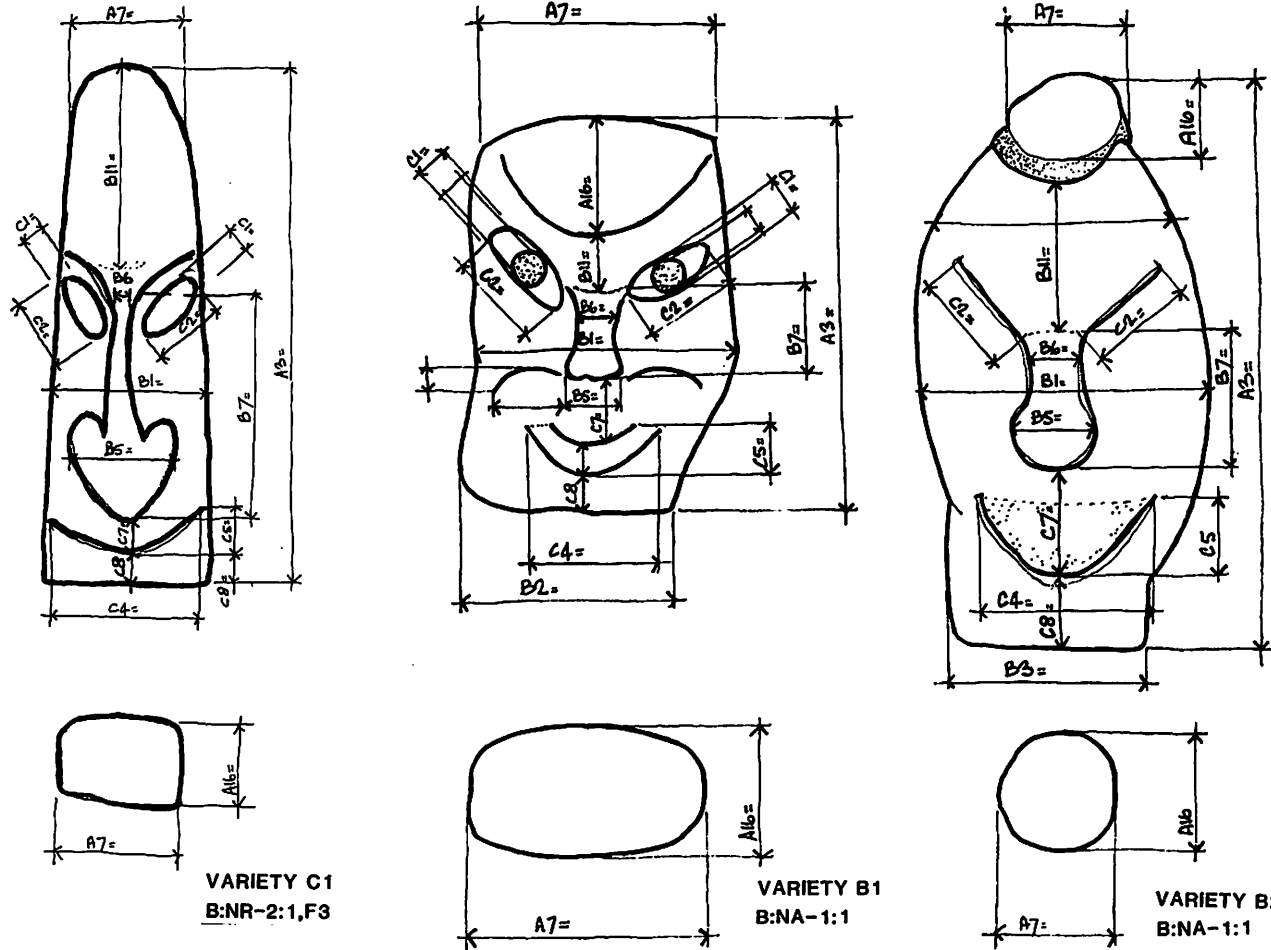

Fig. 3. Categories of metric data recorded on 3 different varieties of Belauan sculpture, 1987.

differential functions and typological classification of one category of discrete nonportable feature: *monolithic* artifacts of stone worked or carved into anthropomorphic form.

"Monolithic" is defined as carved of a single block of stone. In terms of size, all of the monoliths in this study are greater than 40 cm total height. The tallest is 2.93 m total height. Further, monoliths are usually but not always distinguished by the characteristic of being free standing. Variation in scale partially differentiates between a postulated public or private functional nature.

While for the sake of survey location work the category "discrete nonportable" is sufficient to describe monolithic statues as features, it is neither wholly accurate nor appropriate for this study. Accordingly, the term nonportable is not used here because some of the smaller figures are clearly portable and all of the largest are transportable. Further, many of even the larger ones are known to have been moved from their original locations.

Neither are we concerned with stone uprights lacking any anthropomorphic features. Such uprights are classed within the survey as "modifications of stone platforms" and are defined as "large stones, often cut to shape, that stand out from the other rocks in the features. The uprights are sometimes set at the corners of the platform, forming what are often referred to as 'backrests'." (Gumerman et al. 1981:36). Stone uprights described as "eccentric" are "pecked or carved into rectangular or cylindrical columns, and [some] were even carved into statues" (ibid.). Eleven of these "uprights" were documented as part of this study. Data on these are not presented here and "eccentric" is not considered an adequate description.

Based upon a complete review of the literature and a 2 week archaeological reconnaissance in the Belau archipelago, a preliminary classification of monolithic stone sculpture was discerned (Van Tilburg n.d.). A standardized format for the collection of descriptive attribute data was developed (Fig. 3).⁵

The subsequent 6 week field task was to describe each sculpture using essentially 4 methods. Each was 1st photographed in black and white and in a systematic manner from 4 vantage points. Then each was drawn from 1 or more angles (depending upon the features presented) and measured. Observations of context were made and provenience mapped, particularly if the contexts were in any way different or altered from those recorded by Osborne.

A coded list of 10 possible categories of location plus 10 subcategories was developed.⁶ Position (prone, supine, vertical and lateral); cardinal orientation and material (andesite conglomerate, rough andesite, fine-grained andesite, shell, scoria, coral or coral "dripstone") were all noted. Thirteen categories of distinguishing characteristics and/or decorative enhancement were compiled. These included the application of petroglyphs and/or paint, incised lines or cupules, nipples, beard, "headdress," hands/arms, neck or "necklace," "tattoo" (related to petroglyphs and incised lines or cupules but with distinctive or identifiable forms), mouth/teeth/tongue, eye forms, and sexual characteristics.

Data Base

The anthropomorphic stone carvings described in this paper are in the category of what the Belauans call *klidm*, or "face." *Klidm* is a generic classification that includes stones of many

5. During field work on Easter Island from 1981 to 1989, a standardized methodology was developed for recording metrics in discrete categories of formal monolithic sculpture attributes (Van Tilburg 1986, 1987, 1988). Research on Belauan sculpture utilized some of the same measurements and retained the exact computer filing codes (Fig. 4). Measurements were taken in the following categories: A3, A7, A16; B1, B2, B3, B5, B6, B7, B11; C1, C2, C4, C5, C7, C8.

6. Location codes defined were (1) on *bai*, (2) directly related to *bai*, (3) on a stone platform not a *bai*, (4) directly related to any other structure type, (5) general village locus, (6) related to a paved pathway, (7) related to an unpaved trail, (8) related to terrace or field, (9) isolated, unrelated to other features, and (10) repositioned, relocated or restored for conservation or other known purposes.

varying types and sizes, all of which have facial characteristics, no matter how perfunctory (cf. Hidikata 1973b). This paper examines only those that are monolithic (i.e., greater than 40 cm total height).

While the use of the single word *klidm* appears not to acknowledge sculpture attribute classes or distinctions, in actual practice this is not the case. For example, Belauans widely refer to 1 type of sculpture with huge round eyes as *chesuch* or "owl." This term clearly describes the specific sculpture while, at the same time, defining a class of which the sculpture is a member and, more to the point, distinguishing the class from other groups of figures with different (less owl-like) attributes. Similar and less obvious classifications may be made by the Belauans of other types of sculpture, although I am not aware of them.

Our field data from Melekeok and Bairulchau are supplemented by black and white photos graciously provided by Osborne, who excavated these sites. His photos are extremely useful because, although some details of the sculptures have become obscured somewhat over time, they still show clearly in the photos.

BELAU AND MICRONESIA

Micronesia as an ethnographic area encompasses a region of 3 million square miles, of which only 1,045.3 square miles is land (Karolle & Antonelli 1985; Karolle 1987). Within this area there are 2,373 individual islands, islets and reefs that are geographically and politically grouped into distinct entities.

One of these geographic entities, the Caroline Islands, is an enormous east-west archipelago, the westernmost component of which is the Republic of Belau. Belau is approximately 125 miles long and 25 miles wide, consisting of 350 identifiable islands, atolls, islets and reefs totaling 190,655 square miles of land (Karolle 1987:54, citing Bryan). The total enclosed lagoon area is nearly 500 square miles (Karolle 1987:54).

The geology of Belau is varied and complex, as one might expect in an archipelago of its size. Babeldaob (the largest island) is a volcanic "high island" with consequent stone resources, but the small, mushroomlike and wave undercut formations surrounding it and popularly called the "rock islands" (*Chelbacheb*) are coralline limestone (Fig. 4). A variety of other platform reef islands (*motu*) and raised limestone and volcanic formations are scattered throughout the archipelago.

Stone resources are an obvious prerequisite for megalithic construction. Belau, which lies on and partially constitutes what geologists call the andesite line, is richly endowed with a range of andesitic stone types. Yap and Ponape, Belau's near neighbors, also developed impressive stoneworking skills. Nan Madol, on Ponape, is the grandest megalithic achievement in Micronesia (Athens 1986).

Soils on Babeldaob are of the latosol variety and vary in quality (Smith 1983). Belau has a tropical climate and produces such subsistence staples widely cultivated in Micronesia as breadfruit, taro, yams and coconuts. The sweet potato, cassava and maize were introduced after European contact. Fauna of economic importance include dogs, pigs, chickens, several bird species and, on some high islands, fruit bats. Marine resources are widely exploited.

Austronesian Context

The Belauan language is Austronesian, one of the western Micronesian languages in the subgroup Western Malayo-Polynesian, traced back through Proto-Malayo-Polynesian and thence to Proto-Austronesian and Proto-Austro-Thai. Belauan, Yapese and Chamorro in western Micronesia are part of a linguistic subgroup excluding other (nuclear) Micronesian languages while including those of the Philippines, Vietnam, Madagascar, Malaya, Sumatra, Java, Borneo, Sulawesi, Bali, Lombok and western Sumbawa. Within this subgroup, there may be



Fig. 4. Coralline limestone “rock islands.” Photo courtesy Belau Museum.

grounds for a secondary, closer grouping of Belauan with Formosa, the Philippines, northern Sulawesi and northern Borneo (Bellwood 1985:110, citing Sirk; Force & Force 1972:102). Although some aspects of diversity and development of non-nuclear languages remain unclear, linguistic evidence to date “supports present archaeological evidence of western Micronesian derivation from the Philippines or perhaps Indonesia” (Ayres 1978:400).

After many years of archaeological, linguistic and osteological research by many scholars, some generalized aspects of lifeways in early Austronesian societies have been postulated (cf. Goodenough 1955; Howells 1973; Blust 1976). For example, “beliefs centered on spirit animism and ancestor cults are so widespread and deep-seated that they must be of great antiquity” (Bellwood 1985:156). Further, shamans and shamanic practices are strongly indicated. “A dualism of male sky . . . and female earth deities, concepts of supernatural and mystical power . . . and taboo are also virtually pan-Austronesian” (ibid.). Headhunting was apparently widely practiced (ibid.:150–51).

Several important Austronesian societies possessed sociopolitical structures, resource management practices and ideological beliefs that inspired, facilitated and produced megalithic construction. Some of these societies quarried, transported and erected standing monoliths of impressive size. In several loci, monoliths were carved with anthropomorphic attributes and were believed to relate, in various ways, to the spirits of revered and powerful ancestors (cf. Leigh-Theisen 1985; Hoskins 1988:137, fig. 145).

Belauan Prehistory

The outline of Micronesian prehistoric culture is better known on the “high” islands than it is on the coral islands. While the baseline for human penetration of Micronesia appears to be the 1st or 2nd millennium B.C., individual settlement dates at various island locales in western

Micronesia vary rather widely (cf. Fujimura & Alkire [1977] for Lamotrek atoll; Kurashina et al. [1981] for Guam; Takayama [1982] for Yap). As in so many areas of the Pacific, the earliest sites remain somewhat elusive. The oldest dated occupation of Micronesia is in western Micronesia at the Chalan Piao site on Saipan. There, "radio-carbon dates associated with pottery-using peoples [Marianas Red Ware] begin around 1500 B.C." (Ayres 1978:401, citing Spoehr 1957).

Two ceramic traditions, Marianas Red and Marianas Plain, were identified by Spoehr (1957) and have subsequently been clarified through excavation programs (cf. Reinman 1968; Takayama & Egami 1971). Marianas Plain Ware is associated with an aspect of that area's megalithic tradition wherein raised, rectangular structure foundations are delineated by rows of large and heavy stone pillars called *latte*.

There is some tenuous evidence that Austronesian speakers who were horticulturalists and pottery makers settled Belau in the 1st century A.D. (Takayama 1981:88). Thereafter, population movements between the north and south islands (including the "rock islands") seem to have ebbed and flowed. It appears that north and south regions were in sporadic but relatively continuous contact for an unknown period of time (cf. Osborne 1979; Masse et al. 1984).

Belau had a significant prehistoric pottery tradition (Osborne 1966, 1979). The limited research to date on seriation, sequence construction and external connections has not been able to definitively link Belauan pottery to either Marianas Red or Lapita Ware (cf. Bellwood 1979; Masse et al. 1984; Shutler & Marck 1975; Shutler & Shutler 1975; Parmentier 1987:36 for summary). Distribution and style studies seem to suggest the existence of "autonomous centers or chiefdoms located in different areas of the [Belauan] islands" (Gumerman et al. 1981:115). Apparently, "different villages within each of the autonomous [Belauan] chiefdoms may have emphasized different and special functions," thus exploiting a variety of different environments (ibid.).

Belau's megalithic terrace complex raises some highly perplexing questions (Fig. 5). The forms of these earthworks vary, and probable sole functions of defense and habitation seem to have been ruled out (Osborne 1966; Parmentier 1987:31-32). Intensive agricultural use seems more likely, although the evidence is far from conclusive (Lucking 1984). Large group public, ceremonial grounds is at least a possibility. Viewed as architecture, the terraces appear to be "extraordinary sculptures" (Morgan 1988:12). They are remarkably symmetrical in form and appear to have required skills in planning and social organization over several generations (D. Snyder, pers. comm. 1990). A time span of A.D. 400-1400 for construction has been postulated, with probable continuing use for an undefined period of time after the end of active building (ibid.).

The Belauans have, to my knowledge, no generic, descriptive term for the terraces as a group. Their limited inclusion in a few oral traditions suggests that the terraces may be associated in time with 1 type of anthropomorphic stone monolith (Type A) (Parmentier 1987:31). Belauans tend to treat both the terraces and the Type A sculpture as phenomena of the mythic past and do not acknowledge them as artifacts of their ancestral culture. They suggest that the terraces were built by beings that were half-man, half-god. Disowning megalithic remains is not uncommon in Christianized Oceania, and it is not unusual for a people to regard such features as having been built by ghosts or spirits (cf. Christian 1899:170; Harrison 1958).

It has been postulated that Type A sculpture is an "older skeletal style [that] belonged to a people who cleared the hills for terraces and platforms and left potsherds of a rather fine quality" (Chapman 1968:69 paraphrasing Hidikata 1973b:56). Outside Belau, Jensen (1960) postulates a terrace culture that includes field terraces, megalithic monuments and Feasts of Merit for the mountain tribes of northern Luzon and elsewhere.



Fig. 5. Complex of prehistoric terraces in aerial photo taken on Babeldaob during World War II. Photo courtesy National Archives.

Sociopolitical Organization

The 1st western ship to sight Belau was apparently Sir Francis Drake's *Golden Hind* in 1579, although there remains the possibility of an earlier (1526) Portuguese voyage (Wood 1860; Wycherly 1928:91; Lessa 1975). When the English packet *Antelope*, in the service of the East India Company, wrecked on a small island near Oreor in 1783 there existed "a highly stratified society wherein holders of high chiefly titles ruled the land, and were highly competitive among themselves" (Force & Force 1972:8; see also Peacock 1987). The successful cultivation of root and other crops and bountiful marine harvests had yielded "enough surplus so that a complex socioeconomic system involving native currency and produce exchange could be supported" (Force & Force 1972:8).

Chiefly rank was sanctioned by "heredity, age and the supernatural" and was associated with ancestral deities (ibid.:8, 88). The system of social ranking was the "named, exogamous, sometimes totemic, unilinear consanguineal kin group" that shared common descent with all other kin groups (ibid.:32, n.1). Filiation was recognized by Belauans as bilateral with a matrilineal bias (ibid.:42).

Political life was ordered on the basis of the family household (with recognized male head and female counterpart), the clan, the village and the village region. The formal political hierarchy was structured on kin-group alignments with the major political figures being the 1st and 2nd ranked chiefs, with all genealogical links traced to the founding female ancestor.

The chief (*rubak*) functioned as provider and protector who metaphorically "anchors the village polity so that it does not capsize when disturbed by high wind or waves" (Parmentier 1987:69). He was said to be *meang el chad*, "a sacred person" (Force & Force 1972:89). The status elevation of a powerful and accomplished man involved placing a dugong bone bracelet upon his wrist (Wood 1860:448-49). The drawing of a man's hand through the small circlet was, in most cases, an intensely painful experience.

The chief had the right of precedence in resource distribution and ceremonial food preparation. Expressions of respect and deference were paid. His head was never touched as it was the most sacred part of his body. His food was specially prepared and served. He had priority of use over village rights of way and at death was entitled to elaborate funeral ceremonies. The highest ranking chiefs ("four cornerpost" titles) were believed to have a range of supernatural powers and were supported by powerful gods who were *meang* (holy), a term which corresponded "to the *mana* of the Polynesians" (Force & Force 1972:32, citing Kramer 1917-29; Parmentier 1981:146).

Apparently, each village was symbolically divided into 2 nearly equal halves of semistable kin group alignments. This division of village space could occasionally be made visible through the incorporation of a geographical feature such as a river, a road or the configuration of the seashore. It also seems that such a division could be marked by a symbolic feature such as an upright shaped or unshaped stone. While an abstraction on one level, this "concept of duality was one of the most important cultural patterns in Palau, pervading concepts of the physical, social, and psychological worlds" (Force & Force 1972:12). Inherent in the "formalized dual organization" were "institutionalized competitive relationships" (ibid. 1972:76).

The ranking of chiefs within a village was objectified and reflected in formal seating arrangements within the village council house (*bai*). "The council house, like the village, was conceived of as being divided longitudinally into two parts" termed front (*ngelong*) and back (*rebai*) (Force & Force 1972:13). A 2nd, perpendicular line further separated the space into 2 more equal sections, and chiefly seating positions were assigned within these areas. The leaders of the 4 highest ranking sibs in a given village were metaphorically referred to as the "four posts," and

“informants indicated that this reference was to the four corner-posts of a council house” (ibid.).⁷

Barnett (1949:159) says that “all individuals above the age of adolescence, and perhaps younger” were grouped into clubs . . . the sexes were divided by their membership, and there were divisions within the sex dichotomy roughly on the basis of age.” Apparently, each men’s club had a female counterpart and most had a name and perhaps an emblem. Each club “had a war leader who commanded his fellow members on war expeditions” and each was “led by a group of men on a pattern that was a replica of the political organization of the village or district” (ibid.:162).

At the time of contact, Belau was divided into 2 confederacies nearly equal in size. Membership in the confederacies fluctuated as a result of changes at the village region level that were largely a consequence of rivalries, competition and warfare. Control in the north was in the hands of the *reklai* of Melekeok and in the south with the ranking chief (*Ibedul*) of Oreor.

Traditional Beliefs

Belauan traditional beliefs are thought to have centered upon ancestral spirits (those of one’s own family or clan and those of others) and gods (Barnett 1949:201; Force & Force 1972:106, n.5). Spirits of the ancestors were called *bladek* and the gods were called *chelid* (*chelid re beluu* was the village god) (Aoyagi 1987:340). The gods were considered the more powerful since they “had never been men” (Barnett 1949:202).

All gods were able to communicate with the living through shamanistic mediators called *koreng* (ibid.). The *koreng* proclaimed himself/herself both representative of and, on various occasions, the actual god. The presence of the god was made manifest through the physical reactions of the *koreng*. His/her voice and facial expressions became transformed and the entire body convulsed. Such behavior was induced, in part, by the chewing of *betel*.

Mortuary rituals transformed “the dead person’s dangerously proximate ‘ghost’ (*deleb*) into a controllable yet distant ‘ancestral spirit’ (*bladek*)” (Parmentier 1988:283). Ancestral spirits were “considered intermediaries between living people and more formally recognized, named gods (*chelid*), and . . . only high-ranking houses generated significant spirits” (ibid.:292). The result of this change from ghost to ancestral spirit was “an entity which continued to exert powerful forces in the village’s political life. In the domestic context, ancestral spirits played a positive role as guardians of the house, as sources of information and good fortune and as guarantors of generational continuity” (ibid.).

TYPOLOGICAL CLASSIFICATION

The professional literature dealing with archaeological typologies is substantial and has been helpfully reviewed by Miller (1985:2–14) and Whallon and Brown (1982). The classification scheme proposed in this paper seeks to describe attribute variability in very specific detail while, at the same time, avoiding minutia. The goal is to array the material under study within a convenient format that will facilitate a range of further investigations.

While it is true that any classification “captures only a part of the order embedded in material categories and is always from a particular perspective,” it is equally true that artifact “producers cannot be disestablished as the creators of the order” (Miller 1985:11). Thus I do not consider

7. Force and Force (1970:13) give *kloal saos* to mean “four posts”; Parmentier (1987:311) has *eoā el saus* for “four corner posts” and also says that “‘four posts’ is *kleoa el saus*” (pers. comm. 1990). Balauan traditional texts have been interpreted in terms of “cornerpost,” “path” and “sides” models with some “sacred stones” objectifying spatial order (Parmentier 1981:299–301).

the formal variation that is discernable in the artifacts described here to be either accidental or without meaning.

The Belauan monolithic sculpture corpus, as a whole, has not been regarded as a defined tradition reflecting a demonstrable continuity through time in its inherent properties. This was noted by Osborne (1966:475), who recognized a fairly sharp, stylistic division between what he called the "Great Faces" (and what Hidikata [1973b] had earlier called the "large eyeball type") and another group of smaller, finer and more elaborated carvings. On a purely descriptive level, these divisions continue to be logical and are reflected here as Types A and B, respectively.

Even given this basic distinction between Types A and B however, some demonstrable stylistic and functional links definitely exist between these 2 and the other categories of the typology presented here. These links suggest the presence of certain symbolic congruences and continuities, describing and unifying the descriptive type divisions within 1 Belauan sculptural tradition.

The task here is to define style and elucidate function in Belauan monolithic sculpture, recognizing that neither are distinct nor mutually exclusive aspects of form. Style and function are both contained within sculpture form, revealed and expressed in figure design and archaeological context.

The ultimate and richest purpose of this typology is to assist in the daunting research task of "recovering mind" (Leone 1982). Structuralism, ideology and cognition are all theoretical constructs that have been utilized to build innovative approaches to the interpretation of a range of archaeological data. These and other investigative approaches require rigorous descriptions and meaningful classifications of artifacts within substantially inclusive data bases.

As in the classification of all lithic artifacts, the typology presented here is reductive or subtractive in terms of technology utilized. It is based upon an analysis of objectively collected nominal variables that define sets of mutually exclusive properties called attributes (modes). The arrangement of variable attributes defines artifact form and style. Artifact form and style, when combined with observations of archaeological *loci* and ethnohistoric data, reveal certain patterning between the artifacts (sculptures) and their context. It is from these patterns that meaning may be partially discerned.

There are 4 type divisions within this classification scheme (A, B, C, D). Sculptures with attribute variations that resulted in distinguishable statue varieties were 1st grouped into categories called subtypes. This terminology was subsequently abandoned for a number of reasons and, as in pottery analysis, the term variety was chosen to represent categories within type divisions. Thus, there are 3 varieties within Type A, 5 within Type B and 2 within Type C.

Type A "Great Face"

Type A sculptural category contains 18 sculptures ranging in size from a horizontally broken head (PN 16, B:NA-1:1) (40 cm total height) to the standing statue (PN 06, site B:ME-4:2) at Melekeok, which measures 2.93 m total height. These sculptures are, in turn, grouped into three varieties. Type A sculpture is defined by form, features, scale, the material utilized, and the carving techniques employed.

Type A sculptures are carved out of very rough andesite or andesite conglomerate (called "puddingstone" by Osborne 1979:130). Rough andesite is relatively hard and dense but very uneven in surface and color. Andesite conglomerate is rough, lumpy, rather friable, somewhat dense and not consistent in quality of surface. The level of water retention of andesite conglomerate is relatively high, and when sculptures carved of it are in heavy shade they are frequently host to thick, green vegetative cover. Varying degrees of stone quality chosen for sculpture have obvious ramifications for preservation of features.

The sculptures' features are produced through the use of a very rough pecking technique that creates relief. Occasionally incised lines are present. The play of light and shadow on the carved surface is enhanced by both the stone type and the carving technique to produce a powerful image of aggressive impact.

The images are all meant to be experienced frontally. The backs are very roughly finished but are not in any way enhanced. Although Hidikata (1973b:9) says that "they are of relief type or in the round," one would be misled to believe that they are either fully relief in technique or sculpture in the full round. Their size is an important element in their presentation, and these figures define monumentality in Belauan anthropomorphic sculpture.

The eyes are the predominant trait (although not the only facial feature) and show a variety of stylistic treatments. In general, the eyes are created by pecking to give a sunken, roughly circular space that frequently has a round, bas-relief eyeball depicted. Occasionally each sunken space is merely 2 deep and opposing crescent shapes that are not fully connected and between and over which the low relief eyeball has been carved. This is actually a simple carving technique that is somewhat sophisticated in concept.

The sculptures are generally a rounded rectangle in cross section with the top of the head grooved or "dished." Within this type there are a number of innovations incorporating zoomorphic and phallic symbolism that are visually quite startling and impactful given the limited feature range.

The variations in this type category are arranged in ascending order of complexity of compositional symbolism and level of carving techniques employed (i.e., from simple to more complex iconography; from pecking/grooving to evolved bas-relief). Strictly lineal chronological relationships are *not* implied in the ordering of types or varieties.

Variety A1 "Owl"

There are 7 examples recorded for this study. The name "owl" is applied to them because it is currently used for some sculptures in this category by locals; it is descriptive of the form; and because Kramer (1917-29:III, 65) described one of the Ngkeklau sculptures (B:NA-1:1) as "a stone with an owl face." He recorded the name *gesug* for owl while current Belauan usage gives *chesuch*, a name similarly applied to the same variety of figure.

The figures have round, low relief or simply sunken eyes. Either the mouths and noses were never indicated or have been eradicated (mutilated?). The method employed by the carvers is to use a reduction technique to create the convex browline and very slight indication of the nose as 1 unified form. This process creates the space for the eyes, which may or may not be filled with a round, low relief shape representing the eyeball.

The sculptures are rounded rectangle or round in cross section. On 2 of them there is evidence of a wavy, horizontal line across the forehead at the front. This line tends to emphasize both the "hairline" and the brow.

There are no other facial features, although on some of them it is impossible to say that none ever existed. The material is not well-suited for preservation. We sought evidence of deliberate mutilation or elimination of the other features, and on a few pieces such a possibility exists but the evidence is not conclusive.

Hidikata (1973b:18) saw the similarity in form between this type variety and the human skull and believed the type to be "an old one." He described the characteristics as "large eye-sockets and no nose at all. Even if the line of the nose is visible to some extent, there is no shape of any fleshy nose. There is usually no mouth, or even if there is, no outline of the jaws is sculptured." Hidikata is only partially correct in this description in that there are some sculptures that have the nose shaped and defined by the removal of the stone to create the eyes.

One of his drawings illustrates this variety very well (*ibid.*:fig.17). It was said to be "the

goddess *Dirra Mellomes* ("goddess of light"), a name that he did not accept and believed to have been given "by the new society" (ibid.; Parmentier [n.d.:5] gives "Mrs. Bright"). I have not seen this stone, but according to Hidikata's documentation it has no stylistic characteristic that would cause one to describe it as female.

One Variety A1 monolith stands on an old *bai* foundation on the property of the Ingereklii family in Iyebukel (Osborne's K15; PN 03). The figure is very roughly carved. There are some incised lines on the top of the head (vandalism?) and 1 possible cupule. Only the 2 pecked eyes and the line of the nose are visible.

Another sculpture at Osborne's B9 (PN 12; site B:IM-6:1) is badly eroded with few design features visible (Butler 1983). The eyes are round and the right one still shows evidence of a low relief eyeball. The nose is slightly raised. The area of the mouth is badly battered, suggesting that it was either damaged by moving after it was carved or that it was mutilated.

The sculpture stands beside an unpaved trail that one reaches after crossing a small river on a narrow foot bridge (really just a couple of logs thrown across from one side to the other). It is 79 cm total height, and there is a possible cupule or two on the top of the head. Our informant told us that the statue "had always been here." She said that when she was a little girl of 9 she used to play in the area, and the statue "looked the same" (she was about 60 years old in 1987).

Near a modern cemetery at Ngerekngong, Ngeremlengui State stands a sculpture that the locals have long called "the owl" (PN 28) (Figs. 6, 7). Ngerekngong "is a traditional village which is located between Ngermetengel and Ngchemesed in Ngeremlengui" (D. Snyder, pers. comm. 1990). The statue is 1.03 m total height and is in fairly good condition. It has an inclusion at the nose and bas-relief eyeballs are clearly seen.

At Ngkeklaui (PN 16, B34, B:NA-1:1) is a rather small figure that may have been broken in half horizontally, although Hidikata (1973b:44) speculates that another figure just like it on another site "probably was originally carved this way." After examining the figure, it is my opinion that Hidikata may be right. The sculpture has 2 round, low relief eyes and a raised nose. It stands on an ancient terrace with 3 others on a very interesting site associated with a stone pathway "at a place which used to be the *bai* of a former *rubak* (elder)" (Hidikata 1973b:45). The companion sculptures are described in other categories below.

In Ngetpang there is a sculpture standing erect in a densely overgrown area threaded with paved stone walkways (PN 17, B:NT-2:1) (Hidikata 1973b:fig. 15b; Osborne 1966:169-73). It is placed with an uncarved stone and another sculpture classified as Variety B4 and described below. Our informant told us that the statue was known locally as "the owl." Its position is somewhat altered from that reported by Osborne, and it is now 50 to 100 yards south and upslope from the stone platform mapped (ibid.:170). Apparently, its original position was "on a *ked* [bare hill] in Ngeremedangeb" until it was moved as part of spoils of war to Urreked *bai*. Hidikata (1973b:15) says the sculpture is "another *Menga a chui*."

The carving is greatly eroded, with large inclusions in the nose and forehead. Such inclusions, when present, are frequently ignored by the carvers and their unsightliness does not appear to be significant to the design. On only 1 sculpture at Melekeok (PN 09) was an inclusion actually incorporated into the design to enhance the sculpture's visual impact.

Our informant, a very articulate old woman, told us that if a leaf from the *betel* nut palm was placed upon the head of the statue one could cause rain. To stop the rain, one merely removed the palm leaf. She also said that only women were allowed to do this. This may be a condensed and much altered variation on a theme of rainfall included in a longer story recorded by Hidikata (1973b:16) (D. Snyder, pers. comm. 1990, collected still another variation of this story).

Two of the 6 sculptures I documented at Melekeok are placed tentatively in this category (Hidikata 1973b:70-72, fig. 91, b, c; Osborne 1979:130-38). These are PN 07 and PN 08 (Os-

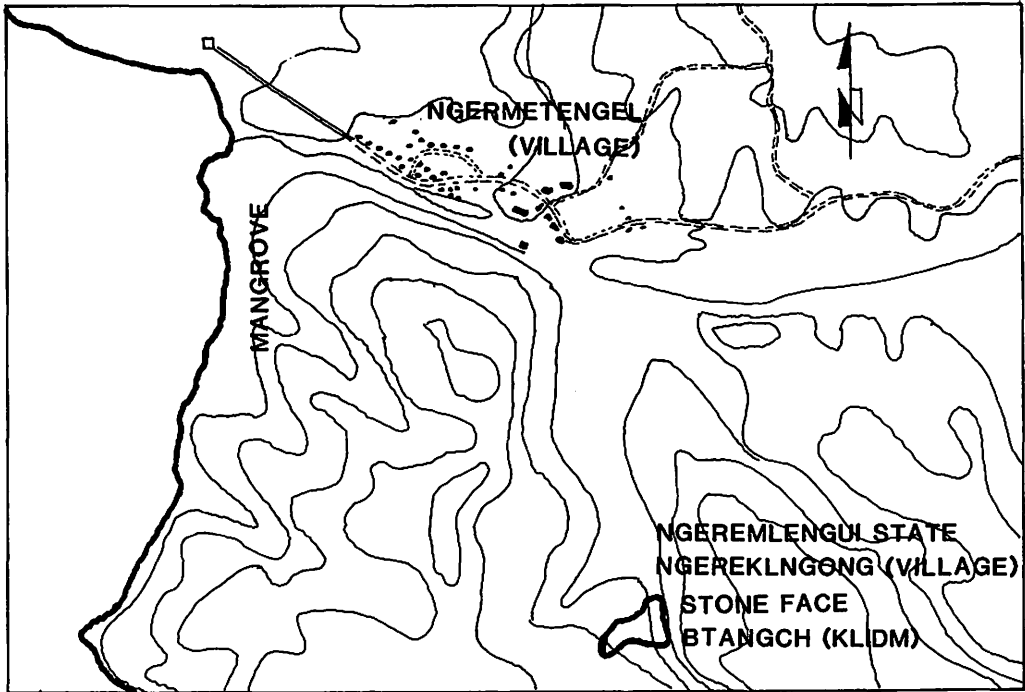

Fig. 6. Location of Variety A1 sculpture. Division of Cultural Affairs.

borne's Stones C and D), which now stand in front of the house of the *rubak* on either side of the gate. We recorded the current positions of the statues (including their relationship to the remains of a rectangular stone platform and a new coastal road). The positions of the 9 original monoliths are reconstructed by Morgan (1988:13) relative to the platform.

Melekeok is an historic village of great political importance in Belau, and its name is now given to an entire state. That state encompasses several smaller named villages, including Ngeremelech, site of 4 Melekeok monoliths documented. Each *rubak* in the area has been drawn from the venerated Secharuleong family, and Melekeok is the home of the *Areklai*, "a man of perhaps the longest lineage and highest standing in the Palaus" (Osborne 1966:242).

The 2 Melekeok sculptures included in this variety may have been greatly altered by time. Osborne (1979:135) thought that "all of the usual characteristics of carving [were] present but they are so thoroughly eroded" that they were not recordable then and are even less so now. If either of these carvings had a mouth, fanged or otherwise, then they belong in another category. I have studied both Osborne's original photos and my own documentation of the pieces and can discern nothing but an indication of pecked eyes, nose in low relief, and curved horizontal line at the forehead. Neither are there mouths present in the drawings done by Hidikata (1973b:71).

I tend to agree with Osborne that, logically, the carvings may have had fanged or toothed mouths. The fact is that neither of them do now nor when Osborne saw them and probably not when Hidikata saw them. If they once did, the mouths "were not accentuated" (ibid.:138). Therefore, both are somewhat tentatively placed within this variety.

The Melekeok sculptures in this category are named, although the antiquity of the names is not known. PN 07 (Osborne's Stone C) is called *Obadebusech*, meaning "Carries Conch Trumpet" or "The Trumpeter" (Hidikata 1973b:72; Parmentier n.d.:9). PN 08 is said to be called



Fig. 7. Variety A1 sculpture at Ngereklingong, Ngeremlengui State (PN 28, total height 1.03 m.). Photo D. Ochsner.

"*Orrenge Chais*," meaning "to hear a rumor" (Hidikata 1973b:72) or "the listener" (Osborne 1966:242) or "hears news" (Parmentier n.d.:11). Hidikata (*ibid.*) speculates on the relationship of these stones to the *rubak* genealogy and family chronology, concluding that all of the Melekeok images "were here long before even Secharuleong entered the area."

There are several other sculptures recorded previously but which I have not personally seen that may fit into this category. For example, 2 at Ollei *bai* appear to be of this variety (Osborne 1979:figs. 170, 187; Hidikata 1973b:57, fig. 75). So, too, do several statues given in Hidikata (1973b:figs. 17, 45, 47b, 54b).

It is possible that there is a Variety A1a. In this category would be placed sculptures with facial features as described for Subtype A1 (eyes/nose) but that may not be heads only. The 1 example that suggests this separate category is at Ollei, and I have not personally seen it. Hidikata (1973b:59, fig. 76b) says it is called the "body of *Osecheluib*." Osborne (1979:fig. 172) suggests that the stone shaft below the facial features may represent the torso.

Variety A2 Quadraped/Face

There are 4 sculptures in this category, although others may exist (cf. Hidikata 1973b:62, fig. 80). These figures are extremely important to understanding and perhaps linking more than 1 aspect of the symbolism presented by the larger corpus. They appear to be transitional in style between the simplified figures of Variety A1 and the more elaborate ones in A3.

The defining characteristic of these figures is that the image is created by carving what Osborne (1966:115–16) called a "quadraped" in bas-relief on a rounded rectangular monolith. The reduction technique produced anthropomorphic features (eyes, nose) on the figure ground and the illusion of the superpositioning of a "quadraped" form. On 2 of the figures, the result is that (1) more than 1 face appears to be indicated; (2) a distinct reference to phallic symbolism is made; and (3) there is a complete formal and symbolic blending of human and apparent zoomorphic attributes and symbolism.

At Ngerbodel Village, Hidikata (1973b:7) recorded a "crocodile stone" called *ius el Bad* (*Bad el ius* by Osborne 1966:fig. 46) and suggested that "the relief below the human face was probably patterned on a crocodile." The story he recorded with this site caused him to speculate that "the *ius el bad* may have been revered as a god of war" (*ibid.*:8). Neither Osborne's documentation nor my own illustrates the stone in the same way and with the same features as does that of Hidikata, who shows a "crocodile" body with a human head/face surmounted by another, smaller "crocodile" type form.⁸ Kramer (1917–29:III, 3) states that this "legend stone" depicts "*Bekkeu Rebodel*" and says that it "shows a moon face with a lizard below it." Apparently, this stone was a gift to the people of Ngarard.

In considering the applicability of the term "crocodile" to the "quadraped" form described in Variety A2 sculpture, we note that the crocodile is an important symbolic element throughout Oceania (cf. Skinner 1964 for Polynesia; Newton 1971 for Melanesia; Best 1988; Kramer 1917–29:V, 17e for Belau). When the form is reduced in scale it is usually regarded as a lizard but still frequently retains its connotation of fierceness. In Belau, marine crocodiles are part of the fauna of the natural world along with at least 2 species of lizard. Lizards, snakes and crocodiles are well represented in the oral literature as well.

In considering the graphic evidence we note that the actual form of the figure does not suggest an anthropomorph. Further, the rounded triangle shape of the head makes the interpre-

8. This stone was lying prone, surrounded by well-tended, flowering plants. The elderly lady who showed it to us said that it was sacred to the *Modekngai* religion, and that if it was touched it would "cause evil," although "white people could touch it." Hijikata (1956:105) shows the lizard form surmounted by an anthropomorphic head nearly completely separated from the body. Hidikata (1973b:7 & cover) has redrawn the figure to show the 2 forms completely connected.



Fig. 8. Variety A2 sculpture ("Mother and Child"), Ngarmid, after clearing, 1960. Photo from color slide courtesy D. Osborne.

tation of crocodile quite acceptable. Finally, when the scale is as large as it is on the Type A figures, the crocodile interpretation is given added credibility.

Notwithstanding all of this evidence, I will retain Osborne's term "quadrapped." My rationale for doing so is my belief that the "quadrapped" form may have assumed variant iconographic/interpretive meanings over time (i.e., a crocodile, a lizard, even a spider). "Quadrapped" is both accurate in description of form and neutral.

The 1st statue in this category is at Ngarmid (PN 04; K3B; B:OR-1:1) and is very famous, known locally as the "mother and child turned to stone" (Snyder 1985:55) (Figs. 8, 9). The name *Dirrangeresauol* ("Mrs. Ngerekesauol") is associated with the statue (Parmentier n.d.:4).

The statue is carved by rough pecking and is very worn and weathered, as it was when Hidikata (1973b:8) described it. His drawings and redrawings illustrate clearly a face formed of 2 eyes and a nose above a defined chin or neck. These features, if they were ever so definitively present, are not now. Either they have eroded away or, more likely, Hidikata's drawings were influenced by informant opinion of what the sculpture was believed to represent.

Kramer (1917-29:V, 254) reports a legend that says that a woman from "Ngarekesauol" returned from fishing and observed *ruk* dancing. Since the woman smelled of saltwater, and the dancers were under a "saltwater tabu," she was ostracized by the group. This angered her so much that she turned herself and her nursing child into stone. Hidikata (1973b:8-9) collected a longer variation on this tale that also states that a woman with a nursing child in her arms had turned to stone. It is his opinion, however, that the story "developed after the original meaning of, or belief in, this consecrated stone image was forgotten" (ibid.:9). Further, he



Fig. 9. Variety A2 sculpture ("Mother and Child"), Ngarmid. Drawing after J.V.T. field data, 1987. C. H. Johnson.

suggests that the stone "was not a god presiding over anything so specialized but a vague god of soul worship in older times" (ibid.). He sees a formal and probably functional similarity between the 4-limbed creature on the "mother and child" statue and the "crocodile stone" (ibid.:fig. 3).

Osborne (1966:115–16) said that locals "state that the stone is a pregnant woman turned to stone." He likened the "child" to a "quadruped" and said that "the quadruped is not an interuterine infant but a crocodile" that he considered to represent a "crocodile biting at a woman's vulva" (an interpretation made today by many Belauans). Osborne suggested a formal resemblance between the statue and a New Guinea menstruation house decoration, indicating "strong Melanesian influence" (ibid.).

The "crocodile vagina" (*eu tsjen*) is, indeed, a common symbolic concept among, for example, the Asmat (Schneebaum 1985:179), while the toothed vagina is generally represented by a clam shell in Belau. After careful scrutiny of the actual sculpture and Osborne's slides after he had cleared and excavated the base, I am convinced of 2 things. First, the creature called a "child" is *not anthropomorphic* in form. Second, the animal is shown with its head *up*, not down. In fact, the head of the animal clearly forms (and visually becomes) the nose of the anthropomorph. The eyes are formed through a reduction technique that, when the stone is chipped away, leaves an indication of the length of the nose. The nose forms and is formed by

the head of the “quadraped,” while the horizontally splayed or out-thrust front legs reach around the face to form the bottom of the anthropomorphic eye sockets. The body of the “quadraped” continues to extend vertically down the face. The tail of the “quadraped” reaches down toward the base of the sculpture. There is no further elaboration of the base to include attributes of a mouth with teeth as one sees on some of the other sculptures in this category.

Both Hidikata and Osborne felt that the story of the “woman and child turned to stone” was a late manifestation. Certainly, the cumulative ethnographic evidence illustrates change in specific story details over time (cf. Hidikata 1973b:18). My own experience at other sites also suggests an evolving or “layered” oral literature connected with the monoliths.

On the other hand, while details collected over time of the “mother and child turned to stone” obviously vary, a certain core meaning remains unchanged. The sense that this core meaning may be of some antiquity is also suggested by 2 very stylized quadraped symbols from *bai* interiors recorded by Kramer (1917–29:doppeltafel 32 a,b), who called them spiders. The same symbols in Belau today are associated with women, children and natural childbirth, and the outline of their forms resembles the “quadraped” at Ngarmid. Oral traditions connect the god *Mengidabrutkoel*, son of *Milad* and said to be in the form of a spider, with human sexuality and procreation (Parmentier 1981:253).

A 3rd *bai* design illustrated by Kramer (ibid.:*bai* 16, c) is also very intriguing. A series of identical headless bodies with bent arms upraised at shoulder level and splayed legs is arrayed in a horizontal format (upraised arms are also a distinctive feature of Belau rock art depictions of anthropomorphs). The legs are drawn with curved lines to suggest buttocks and apparent vulva. The form may be reduced to even further abstraction in a series of chevrons and triangles illustrated in a horizontal band below the apparent anthropomorphs. While the antiquity of none of these particular *bai* designs is known for certain, their posture, form and associated meanings are similar to the “quadraped” described here.

If the formal evidence that the “quadraped” is in an upright position is disregarded and the “crocodile biting at a woman’s vulva” interpretation given credence, it might be suggested that the “quadraped” represents the superimposed form of the god *Mengachui* (“eats hair” [Hidikata 1973b:13]). If so, the statue becomes a complex metaphor that may relate to hereditary male/female descent lines. The defeat or destruction of a chief, club, clan or village by a rival faction may be symbolically depicted, with the devouring of the genitals being a straightforward illusion to subjugation. It should also be noted that contemporary sexual connotations attached to the *Mengachui* symbol involve cunnilingus.

The 2nd example of Variety A2 is located in the vicinity of the old village of Imul, southwestern Babeldaob (Imeliik State)(PN 13; B; IN–1:1). The figure is carved of andesite conglomerate and stands 1.13 m total height (Fig. 10). It is located in a wooded area near the main road and related to the remains of a stone platform.

There are essentially 2 “faces” on this figure, each very similar to the other. The upper “face” is formed by the bas-relief superpositioning of a “quadraped” form to create 2 pecked eyes, the left one still showing evidence of a central, bas-relief eyeball. The nose is indicated and is formed by the body of the “quadraped.” One of the Belauans who showed me this sculpture suggested that it had an ear, although I am not fully convinced. Directly below the nose and eyes of the 1st face lies a 2nd “face” consisting of 2 pecked, rounded and indented areas separated by a raised and slightly protruding “nose” that is also the tail of the “quadraped” (created by the reduction of the stone to form the “eyes”). The resulting impression is distinctly phallic due to both form and positioning. Beneath the “nose” of the 2nd “face” is a curved, bas-relief area that may represent a toothed mouth. The complexity of this carving is such that the 2nd “face” also serves to define the mouth of the primary figure.

There is a further similarity in the mouth of this statue to the “fanged” mouths of Variety



Fig. 10. Variety A2 sculpture, *Imul bai* (PN 13, B:IM-1:1). Drawing after J.V.T. field data, 1987. C. H. Johnson.

A3. In particular, the “tail” of the “quadraped” can be seen as the central “tooth” of the mouth. The interesting thing about this sculpture is that it succeeds in simultaneously evoking the image of a face with open mouth and double face. Incorporated into the mouth aspect is the implied phallic imagery.

The 3rd statue in this category is at Melekeok (B:ME-4:2) (Osborne 1966:242–43, 1979:133–34). It is carved of a good quality, hard and dense andesite that is mottled in color. Given the hardness of the material, it is really only perfunctorily carved. Due to the shallowness of the carving and the condition of the surface, I struggled for a long time with a problem of duplicated or repeated faces. My own documentation, supplemented with photos kindly provided by Osborne, has convinced me of the clear presence of a double face, the lower of which is partly formed by vertical, parallel incised grooves and 2 abraded pits. Double parallel grooves on the chin also appear on Type B sculpture (Hidikata 1973b:fig. 36a). The pit and groove motif placed as it is on this sculpture may also represent male genitalia.

The “impressive supraorbital torus and a complexity of carving or erosion of the upper part of the head . . . defies interpretation except that a double rounding on the top may suggest a coiffure” (Osborne 1979:134). Such a feature is clearly visible in Osborne’s photographs but is no longer so self-evident. My own feeling is that the carving, rather than simply representing either a headdress or dressed hair might also be meant to convey the impression of a human skull, which it does very successfully in photographs. Today the details of the carving are not very distinct, and the upper portion of the head is very difficult to read. There is a formal

relationship of this feature to the horizontal wavy lines on the 2 statues in front of the *rubak* house (PN 07 and PN 08 above).

The eyes on this figure are formed by 2 pecked, opposing vertical crescent shapes that may have had a circular, relief eyeball in the center. Another Melekeok sculpture now lost demonstrates a unique treatment of the eye that consists of “the oval or almond shape, the central boss and ray leading up and out to the forehead and the curving arch which unites the lower borders of the boss and the lower inner border of the eye socket or depression” (Osborne 1979:137–38, figs. 105, 107).

The 4th statue in this category is known to me only through photographs, and I do not have metric documentation. It is located at Ngerutechei (B:NM:10) and has been described as “a *klidm*, meaning it contains the outline of a human face. Its name is *Tmud* and it stands on the platform of Ibungellchang at the west end of the village on the edge of the mangrove channel. It is said to mark the spot where the afterbirth of *Milad* was thrown into the channel” (Lucking 1984:70; Parmentier 1981:269) (Fig. 11).

Milad (“was dead”) was apparently a goddess who was responsible for establishing a quadrartite order in the pan-Belauan sociopolitical context when, after a great flood, she “gave birth to four children in the form of stones” (Parmentier 1987:4). The *Milad* cycle has suggested a relationship between the villages of Ngeremlengui, Melekeok, Imelik and Oreor and some sacred stones (only 1 of which is anthropomorphic). (Hidikata 1973b:83; Parmentier 1981:263).

More importantly for this discussion, *Tmud* appears to present the strongest stylistic evidence for a transitional form between Variety A1 statues and those in the Variety A3 category. Specifically, the eye sockets are nearly perfectly round with bas-relief eyeballs equally round. The upturned mouth is deeply indented and there appears to be a separation between head and body by reduction of stone to create what has been called in another context a “waisted” sculpture form (Harrison 1970).

Nearly precisely in the center of the mouth is a roughly triangular bas-relief form that extends below the line of what would be the lower lip and is incorporated into an extended arm and splayed leg body of what can only be described in this context as a “quadraped.”

The “quadraped” and anthropomorph are separately realized but intimately joined on 1 form. Secondly, the head of the “quadraped” is definitely in the mouth of the anthropomorph, with the shape of the head allowing for a visual reading of “tongue” or “teeth.”

The overall impact is not one of fierceness or threat as one feels in the statues documented in category A3 below. Such characteristics are somewhat alluded to however, especially through what appears to be an emphasis on the head shape of the “quadraped” and on its placement in the mouth of the anthropomorph. The association of this statue with the goddess myth as described above tends to strengthen the interpretation of “mother and child” discussed in relation to the Ngarmid statue (PN 04; K3B; B:OR-1:1).

Variety A3 “Fanged Mouth”

There are 8 sculptures in this category, and 6 of them are at the Bairulchau site (Osborne 1979:174). Their stylistic characteristics include pecked round or slightly oval eyes that may or may not have bas-relief eyeballs indicated.

By far the most impressive sculpture in this category, in terms of scale, is located at Melekeok (PN 06) (Fig. 12). The name of the site where the stone is located is listed on the Palau Register as “*Odalmelech*” (D. Snyder, pers. comm. 1990). Parmentier (n.d.:10) says it is called “*Odalechmelech*” (“Planted at Ngeremelech”). At 2.93 m total height, it is the tallest figure in the corpus. Another sculpture at Melekeok is badly eroded but clearly also within this category (PN 09) (Fig.13).

Bairulchau is the most impressive megalithic site in Belau and the sculptures found there are



Fig. 11. Statue known as "Tmud." Photo courtesy M. Amster.



Fig. 12. Variety A3 sculpture called "Odalechmelech" at Melekeok (PN 06, B:ME-4:2).



Fig. 13. Variety A3 sculpture called "Mengachui" at Melekeok (PN 09; B:ME-4:2).

the most fully realized and detailed of this category (Figs. 14, 15, 16). An open, fanged mouth is present that generally possesses 1 sharply pointed, outwardly curving, long fang on each side. On either side of the mouth are pits or circular depressions. In the middle of the mouth there may or may not be a rectangular or vaguely triangular, bas-relief form that may literally represent a tooth. In some figures a thick, bas-relief, slightly triangular or rounded element incorporated into the mouth appears to be a protruding tongue. On several there are 2 incised or pecked and incised parallel lines below the mouth (as at Melekeok).

In describing the sculptures at Bairulchau, Osborne (1979:161) says:

By far the most striking and obvious characteristic of these unusual carvings are the huge, staring, bulging eyes set beneath a bulging forehead. The nasal and alveolar area is low and curves down to an open mouth with pits at each end and typically three huge teeth or fangs prominently displayed. One is at each side, curving outward below or inside the pits and the third is central. Below the mouth four wide wedge-shaped depressions opposing one another in pairs, apparently form the highly stylized outline of a quadruped, facing

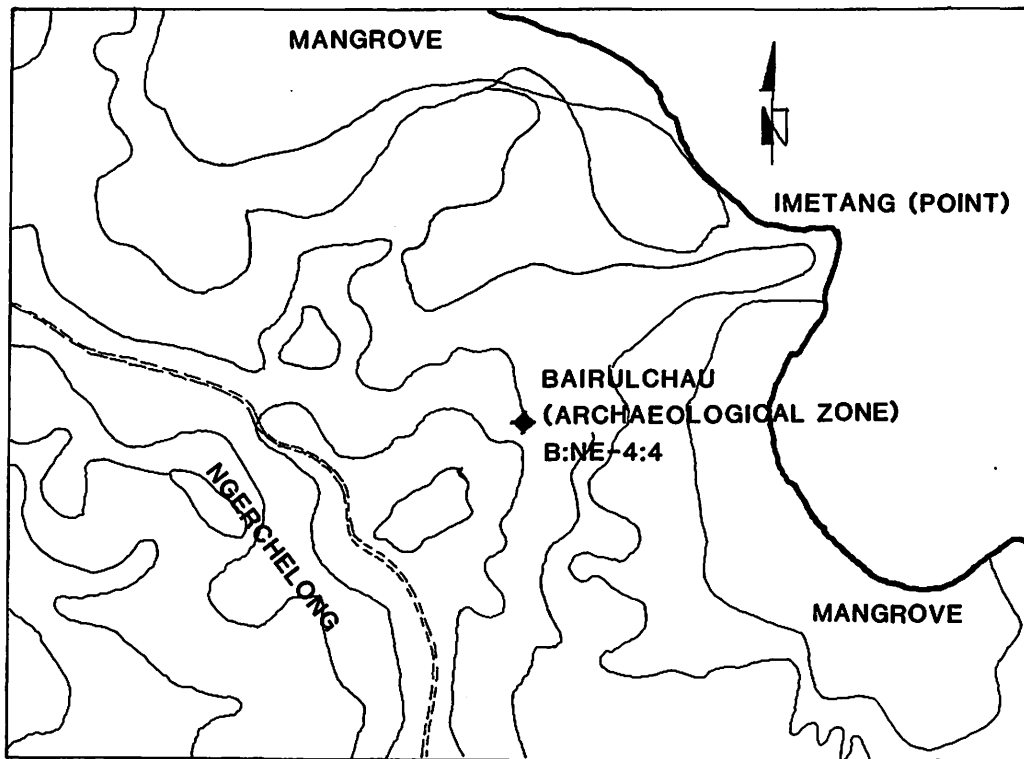

Fig. 14. Map of Bairulchau archaeological zone and environs. Base map USGS, contour level 10 m, datum mean sea level.

up into the mouth of the Being—or they may represent the latter’s genital area.

Osborne (*ibid.*) wondered if the “quadruped-like object” wasn’t a “stylized representation of the more clearly delineated animal figure which I consider to depict a crocodile on the Koror 3 stela” (PN 04, described above). In the case of the Bairulchau sculptures the “quadruped” is certainly formed in bas-relief as Osborne suggested above (i.e., “four wide wedge-shaped depressions opposing one another in pairs”). The body, legs and tail of the creature are very visible in Osborne’s original photographs of the excavated sculptures (less so in the published ones) and can be discerned today with effort on the actual sculptures. It should also be noted that the decidedly upward and outward thrust of the front legs of the quadruped form the outline of the inverted V-shaped, bas-relief tongue of the sculpture and the head is incorporated into the center “tooth.”

The features on all the Bairulchau sculptures appear to me to be a less integrated, more realistic rendering of the “quadruped”/face motif. At Ngarmid, the abstracted “quadruped” shape was large in scale and superimposed upon the basic head shape to form the features of the face. At Bairulchau it has been reduced in size and lowered in position to become a part of and *in the mouth* of the sculptures at Bairulchau, just as it is on *Tmud*.

The archaeological context at Bairulchau is suggested to be a *bai*, and solid dates are still a problem (Osborne 1966, 1979:235–41). There are a total of 52 megaliths on the site, 25 of which are arranged in a 180 foot long linear pattern (Osborne 1979). Other features of this complex site include an earth pyramid, secondary arrangements of megaliths and a plaza.



Fig. 15. View of Bairulchau archaeological zone showing standing megalithic columns. Photo D. Ochsner.

Osborne (1979:179–80) reports a tale that says that the people who built Bairulchau were “like spirits . . . heavily tattooed, extremely hairy, short and dark.” They worked only at night and wore the *ksid* flower in their noses. Morgan (1988:17) presents an idealized reconstruction of the probable *bai* based upon Osborne’s (1979) site map.

Type B “Mask” or “Post” Sculptures

Sculptures in this typological category are very different from those in Type A. They are all smaller and carved from a dense andesite that is smooth and hard. The techniques used to create the figures include highly controlled pecking and abrading to produce bas-relief. They are not faceted but are ground and polished to a superbly smooth finish. The surface richness and elaboration give the figures great vitality. Their execution required a dexterity and high level of competence. As objects, they are refined and elegant by any standard of appreciation.

The dimensionality of the figures is not always fully realized. The natural shape of the stone tends to limit the form of the figure, thus constraining the features to a certain extent. Overall, natural proportions of the facial features are somewhat exaggerated to emphasize the eyes or the mouth, and the face is usually dominated by the eyes, whose shapes vary. In general, these sculptures present a realistic visage that is static and frontal with bilateral symmetry. The head is usually elaborated with “hair,” possible “headdress” or some sort of cylindrical decorative or ceremonial object. While the backs of the sculptures are always finished, the figures are meant to be interpreted frontally (with the obvious exception of sculptures having more than 1 face). The facial expressions are nonaggressive, and some are almost whimsical. They appear personalized and individualistic, bordering on what one might call portraiture. Their presence, achieved in part through their scale and mouth expression, is nonthreatening to the viewer.

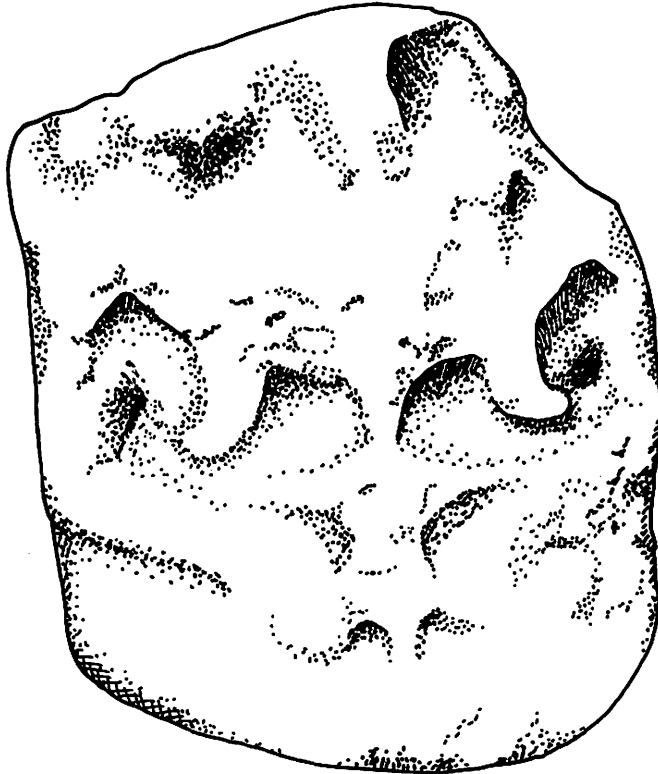

Fig. 16. Variety A3 sculpture at Bairulchau (PN 23; B:NE-4:4). Drawing from J. V. T. field data, 1987. C. H. Johnson.

Types B and C are the finest in terms of the interaction of scale with symbol. The design motifs were expertly manipulated and carving techniques were on a very high level. These figures demonstrate mastery of the medium and control of symbolism illustrated through abstraction. In ancient Belau, evidence suggests that “work patterns not only were determined by special events, but by special skills” and “craft specialists existed” (Force & Force 1972:16). Type B carvings were assuredly created by expert craftspeople who functioned within an established Belauan symbolic tradition. Stylization is evident but so, too, is innovation and individuality. Sculptures in these categories may have been a component of refurbishing or rebuilding stone platforms as part of commemorative or memorial activity.

There are 6 sculptures in the Type B category. There are four varieties within the category.

Variety B1

There are 2 statues in this category. The 1st is the small (total height 63.5 cm) andesite carving at Osborne’s site B1 (1966:158–62, figs. 51a,b) (PN 27, B:NМ-3:1) (Fig. 17). It is this statue that brought me to Belau when I read that “the carving is strikingly like those of Easter Island.” Further, it was described as “more conventionalized” and “less naturalistic” than other statues recorded (Osborne 1966:161).

The sculpture is broken and very worn and eroded, and it is situated today exactly as it was when first described (*ibid.*:160). The statue is called *Iechadrachuolu* (“Mr. Protection”) (Parmentier, pers. comm. 1990).

While the lack of facial features makes this figure difficult to type, it is placed in this category



Fig. 17. Variety B1 sculpture called "Techadrachuoluu" at Imeong (PN 27; B:NM-3:1). Photo D. Ochsner.

because the material, size and treatment of the head (“headdress”) and brow (overhanging) fit with the traits of another figure in the same area that Osborne considered (and I agree) to be “obviously related.”

The destruction of facial features is nearly complete and may, of course, be due in large part to its location facing west on the shoreline at the mouth of the Ngerdong River. I also think, however, that the possibility of deliberate mutilation exists. The issue of “stylization” cannot be addressed at all due to the lack of features, and my overall impression is that the statue is well within the Belauan tradition and closely related in morphology to the other figure in this category.

The 2nd sculpture in this category is also in the Imeong area and has the same site designation (Osborne’s B1 and our PN 02). It is one of the most delightful in the corpus and exhibits a very high standard of workmanship (Fig. 18). The total height of the figure is 53 cm. It is paired as it currently stands on the site with a shaped (“eccentric”) upright stone of distinct phallic form. The material is a dense, smooth and hard andesite of good quality. The name *Ilong* has been recorded for this carving (D. Snyder, pers. comm. 1990). The Belau god *Olungiis* is famous for his “gigantic” penis (Parmentier 1981:253) and might, therefore, be depicted here.

The central feature of the face is the continuous connection of the brow ridge with the length of the nose that is, in turn, connected to the upward curving mouth by a rectangular and naturalistic ridge between nose and upper lip. The resultant, unified form may be a highly abstract and reduced reference to the “quadraped” design documented in Varieties A2 and A3.

The entire figure is carved in bas-relief. The eyes are oval with round pupils indicated. There is a small cylindrical shape on the top of the head. The face appears, both from the front and the back, to be attached to the larger cylindrical column that forms the bulk of the figure. At the back, it is finished near the base in a curved line that may represent a hairline.

This piece is distinctly reminiscent of a style of mask from the Mortlock Islands (cf. Linton & Wingert 1946:74). Some of these masks bear on the top of the head a circular motif that sometimes was made to resemble a human face. The masklike quality of this carving also reminds one of the way in which posts in Micronesian canoe houses are sometimes carved with human faces. Indeed, the formal presentation of this piece from both the front and side is completely like a face carved on a pillar or a mask hung on a pillar rather than being a carved face in the round. It could also symbolically represent a trophy head mounted and displayed on a pole.

The association of the carved piece with the upright, phallic pillar next to it implies symbolic connection. Definition of that connection as “respect” of one stone for another has been suggested and said to be a “basic principle of Belauan sacred stones” (Parmentier, pers. comm. 1990; see also 1987:169). Linkage through “physical connection, proximity or juxtapositioning of human, animals, plants or objects” is explained with the Belauan term “*kabeki*” (Force & Force 1972:102, n.2).

By way of comparison, Harrison (1962:378) says that “a persistent theme of the Malayan megaliths . . . is that they are nearly always ‘paired.’ Two stones, one rather taller than the other, stand together.” Further, he cites local informants’ belief that “the repeated pairing of the stones represented a husband and wife idea” (ibid.:180; cf. pls. XX, XXI). Labang (1962:383) collected a story about “married megaliths” in upland Kalimantan.

It appears that both of the Imeong monoliths were in place on a stone platform. Osborne (1966:160) speculated that the carved face might fit upon the upright and placed it there with some difficulty. There is evidence on 1 other site that suggests placing 1 stone upon another in such a way (Hidikata 1973b:65, fig. 84). I think the objects are 2 separate, symbolically related forms. Placement of 1 atop the other is possible, and certainly may have been done at one time. There is no inherent design feature that would have facilitated doing so, however. The pillar

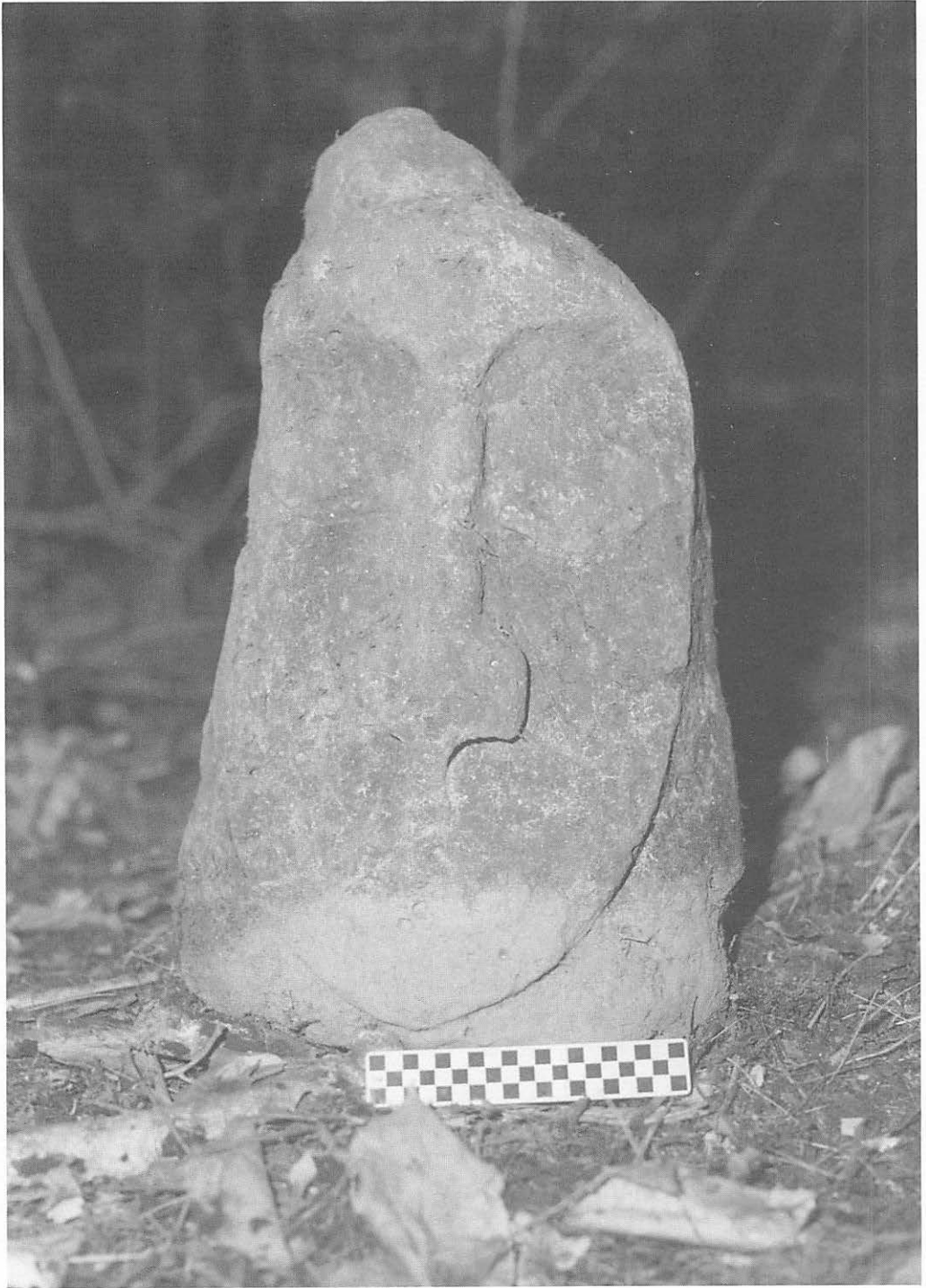

Fig. 18. Variety B1 sculpture at Imeong (PN 02). Photo D. Ochsner.

was assumed to be an “impressionistic representation of the human figure” (ibid.). This may be true, but does not negate its inherent and obvious phallic qualities.

Variety B2

The stone figure that is 1 of 2 pieces in this category is found near a stone pathway at the site of Ngkeklau (B34; B:NA-1:1). It is 1 of 3 anthropomorphic carvings, each classified in a different category, and associated with several other carvings and worked stones that are very interesting in and of themselves.

The features are formed by both pecking and abrading. The eye area is created by pecking away the stone to leave the nose and brow ridge in bas-relief. The eyes, which are oval with round pupils, are incised. Curved incised lines reach from the nares of the nose across the cheeks on both sides. The mouth is very interestingly done with an incised, curved line forming the upper lip and a curved, bas-relief line below.

The sculpture is 56 cm total height and is a rounded rectangle in cross section. It is bulky, but the work is very carefully executed. The overall impression of the face is pleasant and whimsical. No ears are indicated and the cylinder on top of the head that one might expect to find is missing.

This site is described as “on an old *abai* [*bai*] platform high on the first terrace, but still in the jungle” (Osborne 1966:233–34, fig. 72a). The figures are located very near a beautifully paved and stepped pathway. The jungle has been thinned somewhat by small-scale cutting or logging activities. This site is one of the most beautiful I saw in Belau. The village of Ngkeklau is very picturesque and has a lovely old *bai*.

The 4 sculptures on the site have been deliberately grouped and placed in this location. Three of the figures can be described and are placed in 3 different classifications. The 4th is just a small stone that may have been lightly pecked to create 2 small eyes. Associated with the figures is an upright pillar next to which lies a large, flat and triangular piece of smooth andesite. The 2 give the clear impression of a “mast” and “sail,” recalling the idea of the chief as “anchor” (Kramer 1917–29:III, 65; Hidikata 1973b:46).⁹ In addition, another stone placed with it appears to be a grinding stone. The entire composition appears to have an internal, thematic content.

The stylistic relationship of the sculpture that defines this category to the *tridacna* (*kim*) shell carved face at Ngiwal is very clear (Osborne:1966, fig. 72b, c) (Fig. 19). The lines extending from the nose across the cheeks to the sides of the face and the oval eyes with round pupils are closely related in form. The rectangular ridge extending from the bottom of the nose to the top of the upper lip (an exaggeration of an actual trait of the human face) is similar to that found on the carving at B1 (PN 27). In fact, there is a great similarity of the *tridacna* carving as it hangs on a post to the face/post form of the B1 figure. The chief difference is that the shell carving includes a portion of the neck as a stylistic trait.

I should note here that the shell carving has changed since it was photographed by Osborne in 1954. Specifically, shells have been “inlaid” into the cavities drilled to form the pupils of the eyes. The carving is still kept in the home of the same family that has owned it for generations (*Babelblai*). The elderly lady who showed it to me said she couldn’t remember who had put the shells into the eyes, or why. Hidikata (1973b:82–84) discusses the iconographic significance of the eyes of this figure related to the *Milad* cycle.

9. Kramer (1917–29:III, 16) describes a flat stone with 4 holes, each approximately the size of half coconut shells. These were said to hold masts and sails, and the stone was believed to have been in the boat of 1 of the gods during the race of the 7 gods. The stone is located near the *bai* in “*Mangal’lang*.”

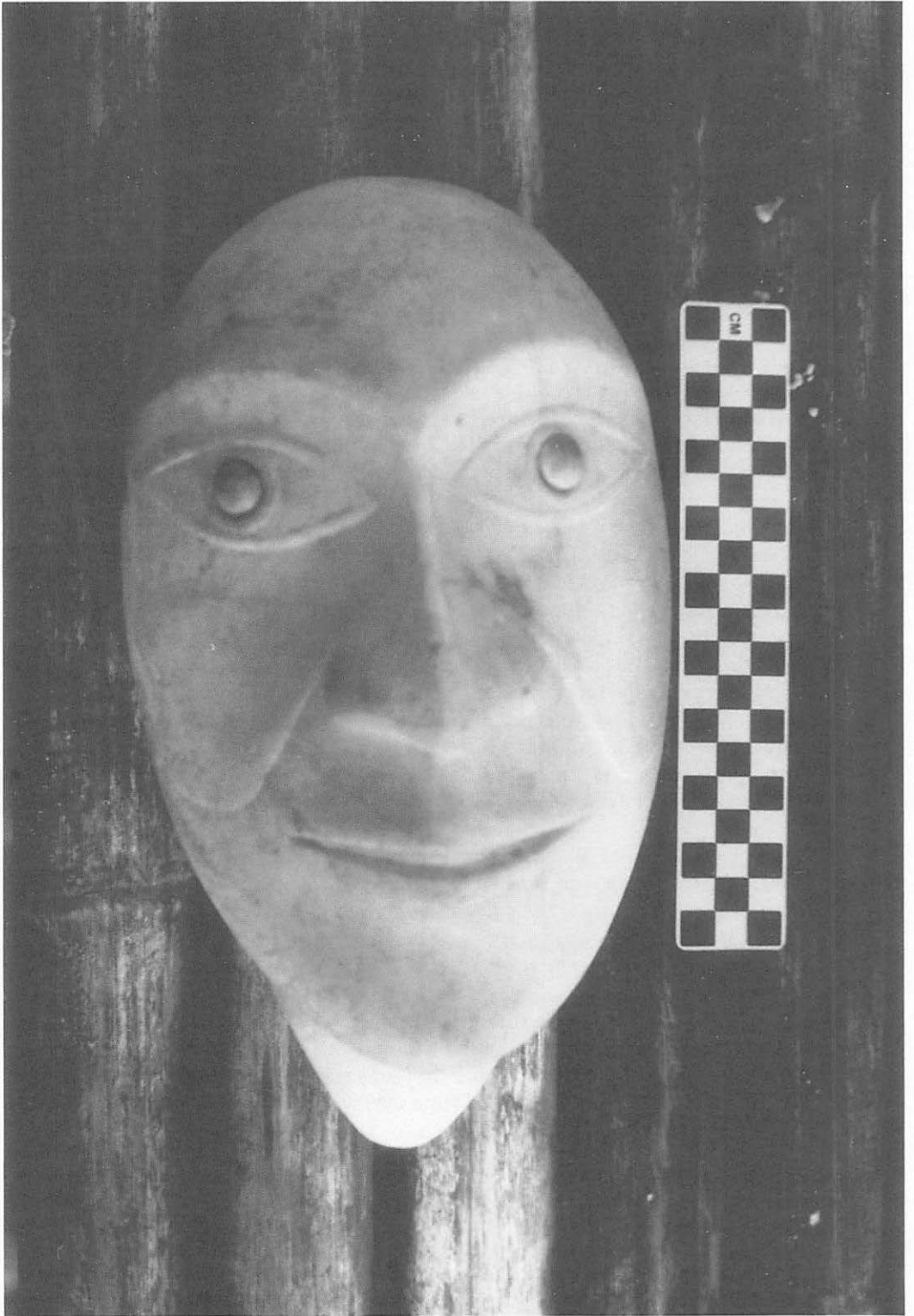

Fig. 19. Carved face of tridacna shell, Ngiwal (B:NI:2) showing inset shell eye detail. Photo D. Ochsner.

Variety B3

There are 3 sculptures in this category, 2 of which I know only from survey photographs. The sculptures are of smooth, highly polished andesite. The prototypical figure in this category is PN 15, B34, B:NA-1:1, 1 of a composition of elements at Ngkeklau that includes 3 other stones with anthropomorphic features.

The features are carved on a vertical cylinder (round in cross section) that measures 75 cm total height. A cylinder shape rests on top of the head at the center, but it is not completely clear that it is part of the head. It may be the top of the “postlike” body of the stone to which the facial features are attached in the “masklike” way as described for B1. It may also represent dressed hair, although most ethnographic materials illustrate Belauan men with their hair tied in the back rather than the front or top of the head (cf. Wood 1860:447; Kramer 1917-29:V; Peacock 1987:64). Force & Force (1972:32, n.5) state that men’s hair styles were symbols of status. In any case, the knob visually resembles a “headdress” while adding to the phallic quality inherent in the overall shape of the piece.

The forehead and nose are formed by the reduction of the surface at the sides. The eyes are no longer visible if, indeed, they ever existed (there is a slight trace of bas-relief, although this is not definite). The pointed chin line is formed in such a way that it may represent a beard (“only a few” Belauan men had “remarkable” beards, Wood 1860:447). At the side, especially at the chin, the face appears spatially distinct from the cylindrical form upon which it is carved.

Osborne (1966:234) was told that this statue was called *Uchel Keklau* or “god of the village” and describes it as “the best example of the art style that I saw.” It is possible that offerings were placed before this sculpture by villagers (and perhaps still are, although we could obtain no definite information on this point. Clearly the “shrine” is as intact today as it was when it was 1st recorded).

There is an unnamed sculpture (B:NC-1:1) that is nearly exactly the same as the one which defines this category (Fig. 20). It measures 90 cm total height and is “found in Ngchesar State, Tmachel Village (Ngersuul). It is found next to a large stone platform, the house platform of one of the highest ranking clans. The village has not been occupied for some time. The carving is executed with large, heavy features, but generally there is symmetry. There is carving only on one side of the stone” (D. Snyder, pers. comm. 1987; see also Snyder 1983).

At the Ngerkedam site in Irrai State (B:IR-3:2) is a site “located on a hill some distance from the mangrove channel. The shrine is located next to the platform of the *bai*, the men’s clubhouse. This would have been a double *bai* suggesting that the village was important at one time. Historically, there is evidence that Ngerkedam was supplanted in importance 1st by Ngerusar and then by Irrai Village during the eighteenth and nineteenth centuries” (D. Snyder, pers. comm. 1987).

“The face is smooth and set off from the stone by the carving. The lines are precisely executed. I believe that at one time the features for the nose, eyes and mouth would have been visible. Like the monolith from Ngardmau, there is a lot of symmetry in the carving. There is carving only on one side” (ibid.). This sculpture is apparently not named.

In all 3 cases, the faces are carved in a “masklike” way similar to that described above at Imeong. Further, the cylindrical and vertical shape presents a suggestively phallic appearance that is enhanced by (and can be interpreted as) the “headdress.” The god name *Mengachui* (“Eats hair”) is sometimes associated with this sculpture subtype (cf. Hidikata 1973b:figs. 11b, 27c, 36a, 48b, 54a, 96a, 102).

Variety B4

This sculpture is near Ngetpang (PN 18; B4) and is paired with another classified as A1 and described above (Fig. 21). Osborne (1966:171) described it as being “a small carved monolith



Fig. 20. Variety B3 sculpture at B:NC-1:1,F.4. Photo courtesy D. Snyder.



Fig. 21. Paired sculptures (Varieties A1 and B4) at Ngetpang with geode in association (B:NT-2:1,F.9). Photo D. Ochsner.

of friable, scaly andesite.” Placed nearby is a stone “which appears to be a part of a geode of bluish agate or chalcedony” (ibid.:170). In Timor, geodes were placed on flat offering stones or altars along with *betal*, areca, lime and other items in order to placate the ancestral ghosts (Hicks 1988:149, fig. 157).

The only facial feature is a bas-relief V-shaped area some 11 cm across at the widest (top) portion. “Most interesting is the representation of a cord around the neck of the carving (in front only) which carries in its center the representation of an object which can only be a piece of the large Palau money. Probably the stone represents a woman” (Osborne 1966:171). According to recent ethnographic data, the stone is said to be called “*Mother Medecheibelau*” (Strack 1990).

The abstract depiction of female sexuality through such symbolism (Belauan money) implies the inherent concern of the carver and society with depicting rank and status through the display of wealth. Women were paid for their services as experts with supernatural powers (sorcerers, diviners) or as resident concubines in men’s clubhouses (Force & Force 1972:17, 23). Such concubines either went to men’s clubhouses on their own initiative or that of their families. Sometimes they were taken during intervillage warfare. The wealth and status a successful concubine amassed also lifted the social status of her family.

Only women “of high rank” were permitted to wear money (Force & Force 1972:32, n.5). Some Belauan families who possessed money were forced to bury it to protect it, and “protracted possession of money pieces by those who were not of wealthy status was uncommon, since fining and other practices allowed powerful chiefs to pre-empt Palauan money pieces” (ibid.n.6).

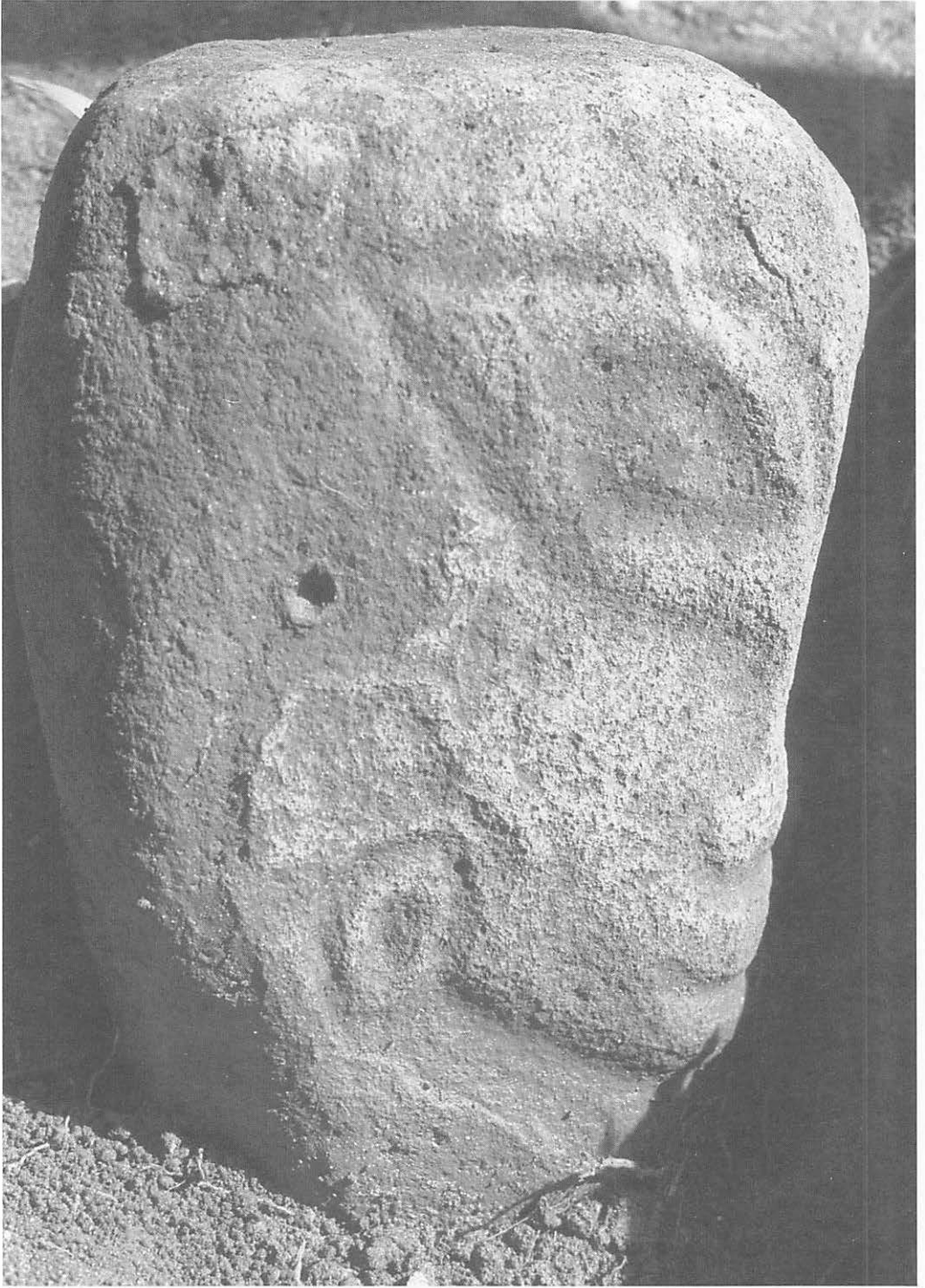

Fig. 22. Profile view of Melekeok sculpture (PN 10, B:ME-3:1). Photo D. Ochsner.

The Belauan money symbol is carved upon an upright, phallic and otherwise unenhanced "pillar." There is thus either a kind of sexual ambiguity or sexual integration presented in the carving as a whole. This is further suggested by the fact that the V-shaped area described above is very similar to other sculptures where the same form more fully suggests a "beard." In fact, the form is equally representative of either a "beard" (male) or unbearded "chin" on all figures where it appears.

At Ngerdimes Village, Ngcheangel (Kayangel state) Osborne (1966:303, fig. 93a) saw and photographed but did not otherwise document a stone "said to be *Dirrabakaruus*" that apparently had 2 faces (see below) and a "peculiar bib below the chin." It is at least possible that the "bib" is really another abstraction of Belauan money as in the "female" figure from Ngetpang.

Variety B5

There is only 1 sculpture in this category, but it is described fully here for the 1st time and is, perhaps, the finest example of stonework yet known from Belau (Figs. 22, 23). It is in Melekeok, found at the back of the *Omenckengkar* family home in the village (PN 10, B37, B:ME-3:1).¹⁰ It also appears to be the one Hidikata (1973b:72, fig. 92) called "another of the stone images of the god *Menga Chui*." The original drawing (Hidikata 1956:143) is far superior in detail.

The face is expertly carved on smooth and regular andesite and measures 42.3 cm total height. All of the carving is in bas-relief with incised and abraded grooves at the eyes and mouth and 1 drilled cupule on the side of the head. The finished surface has been ground and polished.

Its sculptural traits are well within those established for the Belauan sculptural tradition reported here. The figure is unique in its artistic merit realized through an accomplished use of space, design motif and technique. Further, the articulation of design elements is so expert that some of them can almost stand as prototypical of similar elements that are either exaggerated and abstract, poorly done or poorly preserved on other sculptures. For example, this sculpture has a single, bas-relief circle on either side of the mouth at the jaw. This circle may relate in form and meaning to the indented, circular "pits" that are larger and more ragged (due to scale, material and technique) on the much larger sculptures at Melekeok and Bairulchau. These pits are placed in the same location on all of the sculptures (i.e., at the sides of their mouths).

Another trait suggested on other sculptures but which is here fully expressed is the unified symbolism of the 2 eyes and the nose. In this piece, these 3 features are clearly expected to be perceived as 1 symbolic unit. The nose is splayed and flat at the nares, circumscribed by the natural limits of the stone shape. The figure is not fully sculptural but has a distinct and latent three dimensionality.

The shape of the stone utilized to carve this figure is somewhat unique in that it is triangular in cross section. The face thus "wraps around" the stone with the nose along 1 of the side axes and the eyes extending up and along each plane side. The piece is fully frontal and the back unenhanced. Because of the eye treatment, the carving at the neck and the lack of any elaboration of the back of the head, this sculpture has masklike qualities similar to that noted on other pieces above. Such qualities are not fully expressed, however, and are not as strongly stated as they are, for example, on the carving at Imeong.

Type C Multiple Faces

The figures placed within this type category are unambiguous. The illusion of a double face created by subtle and cunning use of bas-relief in such carvings as those of Variety A2 above

10. The Melekeok sculpture was found as a result of the fine detective work done by Marty Gonzalez, M.A. and her crew of Belauan high school students with the help of Kempis Mad.

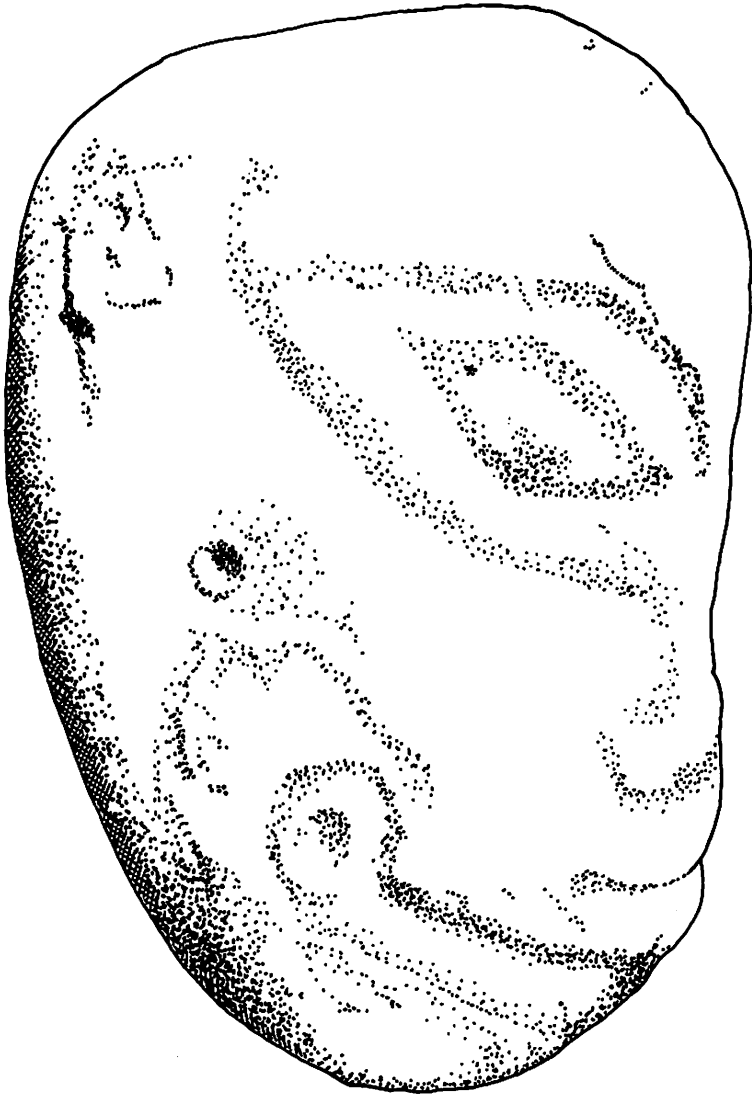

Fig. 23. Melekeok sculpture (PN 10). Drawing after J. V.T. field data, 1987. C. H. Johnson.

are not included. In all cases, the faces are on opposing sides of double- or quadruple-sided columns and there is no doubt that the carver intended to represent more than 1 face as a discrete component of the single, upright "post" design. There is no clear evidence to suggest the temporal relationships of different faces on the same "post." Differential weathering may indicate that only 1 face was carved at a time, but it is impossible to say for certain.

There are only 2 examples in this type category, although there are assuredly more that I have not seen. Hidikata (1973b:36, no. 5; 47, fig. 59, no.2; 74, fig. 96b) provides additional data on double-faced images. The name "*Temdoki*" is associated both with multiple face images and very small, carved human heads. *Temdoki* was a guardian spirit of villages "whose duty it was to keep watch over things inside and outside the settlement and report any trouble" (Hidikata 1973b:35).

Because of the stylistic similarities (in fact, near duplication) of the faces when they occur

on the same form, I don't think that multiple faces necessarily suggest the representation of more than one being. Indeed, both the pairing of individual figures on the same site and multiple face carvings may be an echo of Belauan philosophical dualism.

Variety C1 Two Faces

The 1 figure in this category is located in Ngardmau, in Ngerutoi Village (Osborne's B23, PN 25, survey site number B:NR-2:1, F.3) (Figs. 24, 25). Hidikata (1973b:24) says that a family named *Kerong* came to Ngardmau from Ngeruangel. He notes that *kerong* "signifies a shrine or shrine priest." The family was associated with sacred stones and was thought to be traditionally "one of priests" (ibid.).

The Ngardmau sculpture has had several names, 1 of which is *Ngchedub ra Ielch*, which means "recognizing the chief" (Snyder 1983:28). The name "*Beduk liel*" was recorded earlier (Hidikata 1973b:22, fig. 23). Hidikata (ibid.) reports that "it was said that this stone made judgment on the *Tewid Lobak* (seven elders), although the story may well be of recent origin. *Dub* means source of plant growth, so the name translates as 'growth of liel'." (Hidikata [ibid.] modestly says "I did not ask what was meant by *liel*" but assumes its phallic meaning.) I was given the name *Dubraielch*.

It should be noted that Hidikata's (1973b) sketch gives a dimension of 9 m for this figure that is wholly inaccurate. Measurement of the same carving in Hijikata (1956) is given as 3 (presumably meters). My measurement is 82.5 cm total height.

The site is described as an "old paved area [dock]; in front of it was set a small, roughly cylindrical stone on which a face had been carved" (Osborne 1966:215-17; Hidikata 1973b:22; Snyder 1983:28). Osborne (1966:fig. 68) sketches a face that is not described as 1 of 2 on the same figure and the sketch does not resemble mine, which is certainly the same as that recorded by Snyder. There is thus some discrepancy here in documentation.

In any case, the faces are carved using a bas-relief technique enhanced by grinding and polishing to produce a smooth and even finish. The eyes are oval and slanted upwards, and abraded grooves form the slanted brow line. The faces are on the east and west side of the post and are very nearly identical with only a slight difference in metrics. The preservation of the west face is superior to that of the east face. The 2 faces are visually connected in that 3 of the 4 lines defining the eyes continue on both sides until they meet at the indented midsection of the sculpture. The left eye of the east face is incomplete.

On both faces, the nose is long and pendant, formed in bas-relief. The length of the nose is disproportionate to the other facial features. The nares are decidedly arrow or heart shaped and the mouth is only lightly indicated by an incised line. A curved line cut in bas-relief at a point 8 cm above the base of the sculpture may indicate the chin or represent a "beard."

The upright stone is incised and worked at the top. A groove 7 cm deep runs across the top horizontally. The distinct impression is phallic, and Hidikata (1973b:22) says that this stone "from the side clearly looks as though it were a typical stone phallus. There are many stone phalli in the islands."

Uprights lacking facial features but variously described as "bifurcated" (Osborne 1966:206, fig. 64c) or "forked" (Hidikata 1973b:39, fig. 45c) are formally related to Variety C1 monoliths with anthropomorphic faces. The "forked" (phallic) attribute might parallel the iconographic nature of the crocodile in that in some areas the "lizard" is depicted with a forked tail and is considered phallic (cf. Leigh-Theisen 1985:83). Parmentier (n.d.) says that a "forked stone" is called *metengetang*.

The locals informed me that the sculpture represents either 2 chiefs or 2 names for 1 chief (there was some heated discussion on this important point). Apparently the god of Ngardmau was thought to enter the stone.

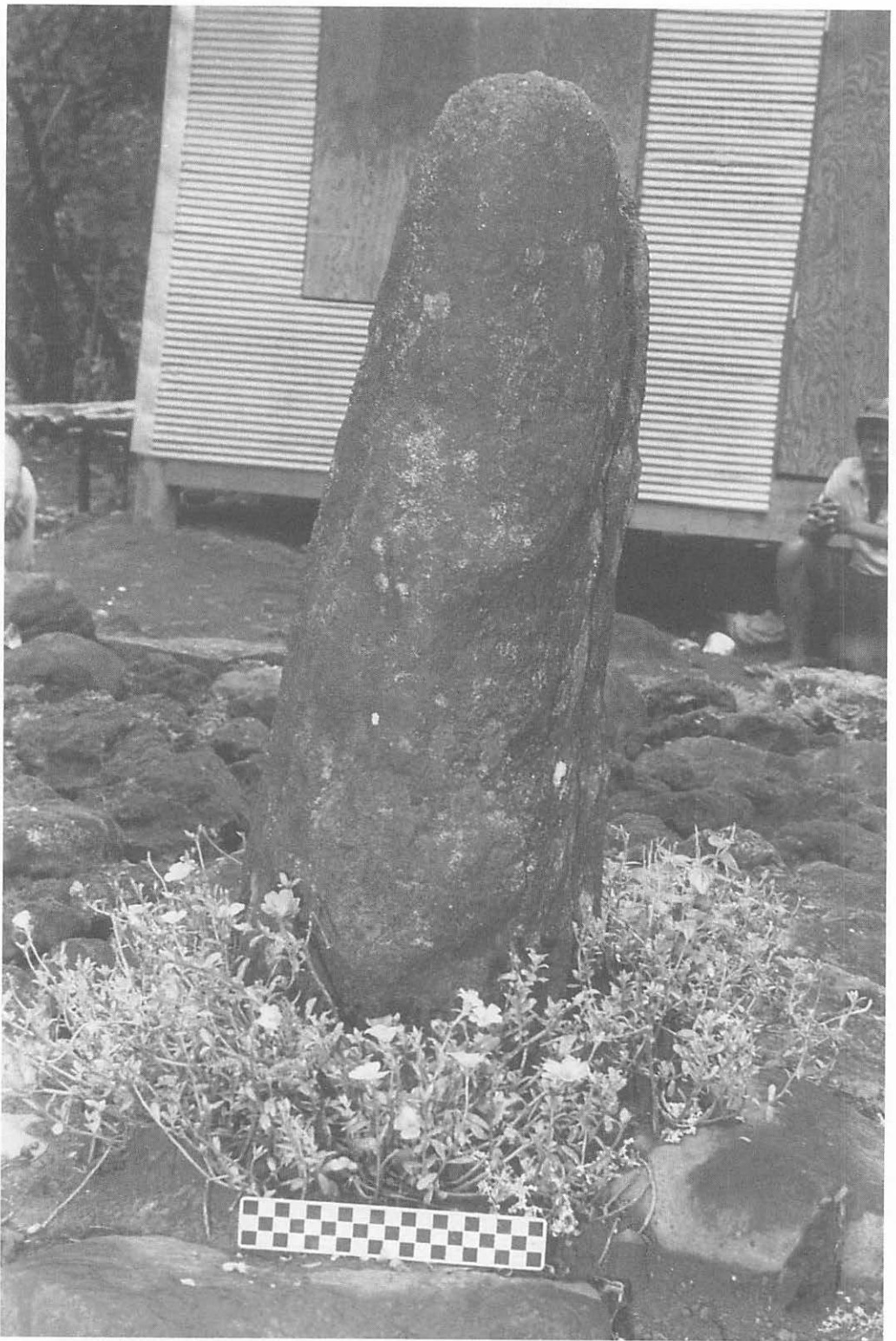

Fig. 24. West face of Variety C1 sculpture, Ngardmau (PN 25; B:NR-2:1,F.3). Photo D. Ochsner.



Fig. 25. Profile view, Variety C1 sculpture, Ngardmau (PN 25; B:NR-2:1,F.3). Photo D. Ochsner.

At Ngerdimes Village, Ngcheangel (see above) is a possible female statue said to be *Dir-rabakaruus* that is apparently “a Janus-faced stone, although one side is infinitely more finished than the other” (Osborne 1966:309, fig. 93a). Further, it would appear that “the second face, although in the same outline, had been added long after the first was done” (ibid.). It was located when Osborne saw it “near the home of the leading man of Kayangel” (ibid.). According to Parmentier (n.d.:4) the stone is related to the story of *Orachel*.

Variety C2 Four Faces

This very interesting sculpture (PN 26) stands today in exactly the same place where it was recorded as Site B29, Airai State, Babeldaob Island, by Osborne (1966:222). Hidikata (1973b:9) locates the figure at Ngarmid on Oreor Island where he says he saw it “standing on the site of an ancient shrine . . . called an *ulengang* [that] did not belong to the settlement but was owned by a private person.” It seems that Hidikata got the location wrong.

The figure is now very badly eroded and quite covered with lichen. The faces on the north and west are only visible in outline. The face on the east presents an outline of the eyes. The south face is the most clear (as it was when Osborne saw it). It is impossible today to state the sex of the figures. Hidikata (ibid.; the better drawing is in 1956) shows breasts on 2 of the figures and says that the “right and left faces were female.” Osborne (1966:222) says that “the west face is clearly that of a female; the eastern is broken and eroded but does not appear to have represented a woman, while the northerly face is a less well-finished duplicate of the southern.”

More interesting than the presence or absence of breasts depicting femaleness is the bas-relief, squared “yoke” carved below the chins of 2 of the images (1 male and 1 female) and visible in Osborne’s original photos. My 1st thought was that the representation was an abstraction of Belauan money as discussed above. I now tend to think that, on the male figures at least, it may represent the neck of the image in much the same way that the Ngiwal shell face has a neck indicated.

The pillar or post on which the 4 faces are carved is decidedly phallic. It is a rounded oval in cross section or roughly cylindrical in overall shape. The pillar is abraded to form a groove across the top. This multiface image is distinctly similar in style to the “mask” or “post” figures above.

The eyes of the most well-preserved (south) image are oval, carved in bas-relief and connected as 1 unit with the nose. The mouth is a horizontal oval with lips and tongue indicated. All of the images, as far as I can make out now, must have been similar. The overall proportions are comparable.

The stone platform on which the figure stands has been damaged, as has the top of the statue’s head. Because the image and the platform are located under a stand of *betal* palm where little sun penetrates, the lichen and moss on the sculpture are very heavy.

The name of the family on whose property the image stands is Ngirkiland. I was told that the name of the statue was *Medechiibelau*, which is the name of the god of Airai State (see also Kesolei 1975:6). *Medechiibelau* was said to be worshiped by head chiefs and priests. People used to give offerings of barracuda and dugong to the sculpture, and “some of the people of Airai believe in the god still.” I was also told that another sculpture had once stood on the opposite corner of the platform.

Today, the stone platform is apparently used for dancing. The dance performed is “very special” and is called *Altamumeu*(?). People link arms and dance around and upon the lower (*Ioulsob*) platform while the chief sits on the upper platform. The dance was last held in 1932 (Van Tilburg field notes 1987).

Type D

I have documented only 1 statue on Belau that unambiguously consists of head and torso carved out of 1 piece of stone. One statue, of course, cannot constitute a type. I justify the creation of a type category here because at least 1 other such statue has been reported (cf. Osborne 1966:172, fig. 55c) (Fig. 26). Further, pending more study, the statue called *Tmud* may also be a head/torso figure.

The sculpture that defines this category stands in the village of Ngerbodol, on the corner of a *bai* platform (Snyder 1985:93). "It is formed of a large piece of dripstone, probably from a coral cave. The figure is in such poor repair that few stylistic features are discernible. The right ear has been broken away and a large solution cavity disfigures the right side of the face" (Osborne 1966:143, 141, fig. 45).

The figure is very weathered. The bas-relief, oval left eye is still visible, as is the outline of the mouth, ear and nose. It appears at least possible that arms were traced along the sides of the figure with incised lines and slight bas-relief at the front, but it is impossible to say for certain.

COMPARATIVE ANALYSIS

Within Belauan rock art, attempts have been made to seek extraisland parallels for some design motives in Indonesia (Osborne & Gregory 1979) and Melanesia (McKnight 1970:pl.5, which he suggests is a "mask" related to "aspects of Melanesian art"). Depiction of fully anthropomorphic forms is rare, while disembodied anthropomorphic features such as hands, feet, and eyes are more common.

My own analysis is that anthropomorphs in Belauan rock art are depicted in a range of realistic to highly abstract forms (Fig. 27). As in many *bai* designs, the preferred pose is frontal with upraised arms, and vertical streamer-type elements (generally regarded as a sign of shamanic power) often extend from the tops of heads (cf. McKnight 1970: pls. 1, 7, 8a). Facial features are usually reduced to the eyes and nose, and sex is frequently but usually subtly or abstractly indicated (Fig. 27a). In my opinion, Belauan rock art has not been fully recorded. My own investigations reveal that 4 of 6 reported rock art sites are nearly lost to weathering. Thus, 100% recovery of the symbols is not likely. I do not agree that Belauan rock art "does not reflect a recognizable stylistic affinity to any known ethnographic art in the area" (Osborne & Gregory 1979:299). Instead, I suggest an iconographic relationship, in the case of human figures, to *bai* designs. Further, I believe there is a continuity of meaning and emphasis that extends to Types A and B sculpture.

Kramer (1917-26) presents a rich and significant collection of *bai* designs, and some of the anthropomorphic heads he depicts are extremely interesting. Two are elongated and stylized with the hair tied up on top of the head in the fashion suggested by Type C sculpture (Kramer 1917-29:doppeltaffel 32k, p), and several are associated with the names of gods.

In terms of extra-Belauan affinities, Bellwood (1979:287) has suggested a stylistic relationship between some Belauan stone carvings and those of Unea Island in western Melanesia. Hidikata (Hijikata 1956:103) felt that Belauan stone images belonged to "a particular culture presumably derived from Celebes." Osborne (1979:266) suggested that the megalithic sculptures of Sulawesi were most like those of Belau.

The Unea Island sculptures are commonly called the "Malangai Stones" (Riebe 1967). They are all located in the general vicinity of the village of Malangai and consist of faces carved into the surfaces of boulders, generally using bas-relief techniques and often incorporating the natural contours of the rock to create the features.¹¹ None of the "Malangai Stones" are related

11. Boulders carved in the form of bas-relief anthropomorphic faces occur on Easter Island (Lee 1986:79-80, 126, fig. 40) and are ethnographically related to the creator god *Make Make* (and, by extension, the birdman cult).



Fig. 26. Type D sculpture (head and torso intact) on *bai*, Ngerbodel (PN 01, B:OR-3:6). Photo D. Ochsner.

to architecture, but apparently there is an ethnographic association with fertility practices or agricultural increase.

There is a superficial stylistic relationship between the Unean carvings and those of Belau Type B. The features of the Unean carvings are centered on the knife edge of the boulder, which allows for the use of opposing, flattened planes in an impactful way. This technique is similar to that employed on PN 10, Variety B5. Unean sculpture is differentiated from Belauan by the use of distinct chevron forms at the eyes and nostrils, the treatment of the mouths, and the lack of phallic symbolism in the formation of the nose. The perfunctory utilization of the generally unshaped boulder as a sculptural form also varies from Belauan style. Campbell (1971:76) finds the fineness of detail in the treatment of facial features on Unean figures to be unlike other Melanesian stone images and suggests that an Austronesian comparison would be more beneficial.

Montvel-Cohen (1987:13) suggests that Belauan "stone monoliths" emphasize "a stylized human face suggestive of Sepik River wood art." The most prominent of all individual features in Sepik River art is the nose, and some Belauan sculptures share this general stylistic emphasis (cf. Newton 1979, fig. 2-3 as compared to fig. 3 suggests a fairly strong relationship). The sense of the dramatic is very strong in all Sepik River art, and both large, public and more personal or hidden sacred images were created (Newton 1971, 1979).

However, in Sepik River art "the diversity of conventions used in the representation of facial features and parts of the human body is truly bewildering. Eyes, for example, appear as pin-points or as huge circles, as narrow slits or as wide ovals. Heads may be round, oval or diamond-shaped and arms and legs vary from long thin stems to massive stumps. These stylizations appear on figures in countless combinations and make it very difficult in some cases to ascribe specific styles to specific groups" (Linton & Wingert 1946:109). Such a rich corpus might quite naturally offer comparative similarities.

"Most of the recorded stone carvings along the Sepik and north of it are in effect decorated monoliths" (Newton 1979:33). The Sepik Hills region, including the river and plains to the north, "seems to have a fairly rich tradition of carved or uncarved (and in that case possibly painted) monoliths and small analogs of monoliths" (i.e., portable stone carvings) (*ibid.*). Tentative stylistic categories for the Highlands include a heterogeneous group of carved stone human figures that range from "distinct naturalism to a moderate degree of stylization" (*ibid.*:40). All are generally believed to be of considerable but unknown antiquity.

Neither the published object numbers of Melanesian stonecarvings in general nor their stylistic range compares with that of Melanesian woodcarving traditions. The common physical characteristics of all reported stone anthropomorphic sculpture from Melanesia are round or oval heads, with those from the New Hebrides being elongated and phallic. Most known examples are portable and were surface collected or traded and are not well documented archaeologically. In general, the stylistic diversity of figures reflects wood carving traditions in each area (cf. Bulmer & Bulmer 1962; Campbell 1971).

The crocodile is a known iconographic motif in Melanesia and is usually depicted as an ancestral totem. One canoe house post from the Solomons depicts a crocodile in splayed-leg posture, head up, on the front of a male anthropomorph (Meyn 1982:22, fig. 1.2). Among the Asmat, crocodiles are depicted on pole carvings and shields (Schneebaum 1985:99, 179). There is an extensive oral literature dealing with the crocodile as a symbolic being. Masks from the Papuan Gulf (*ibid.*:97) may have open jaws filled with teeth that resemble those of a crocodile. One mask from Malekula Island, New Hebrides, has curved "fangs" or "tusks" (Meyn 1982:pl. 1). Such masks, "which are worn by men, signify distinct grades or prestigious ranks in the society" (*ibid.*). The depiction of fangs may relate, in Melanesia, to either pigs (as tusks) or crocodiles, depending on the area.

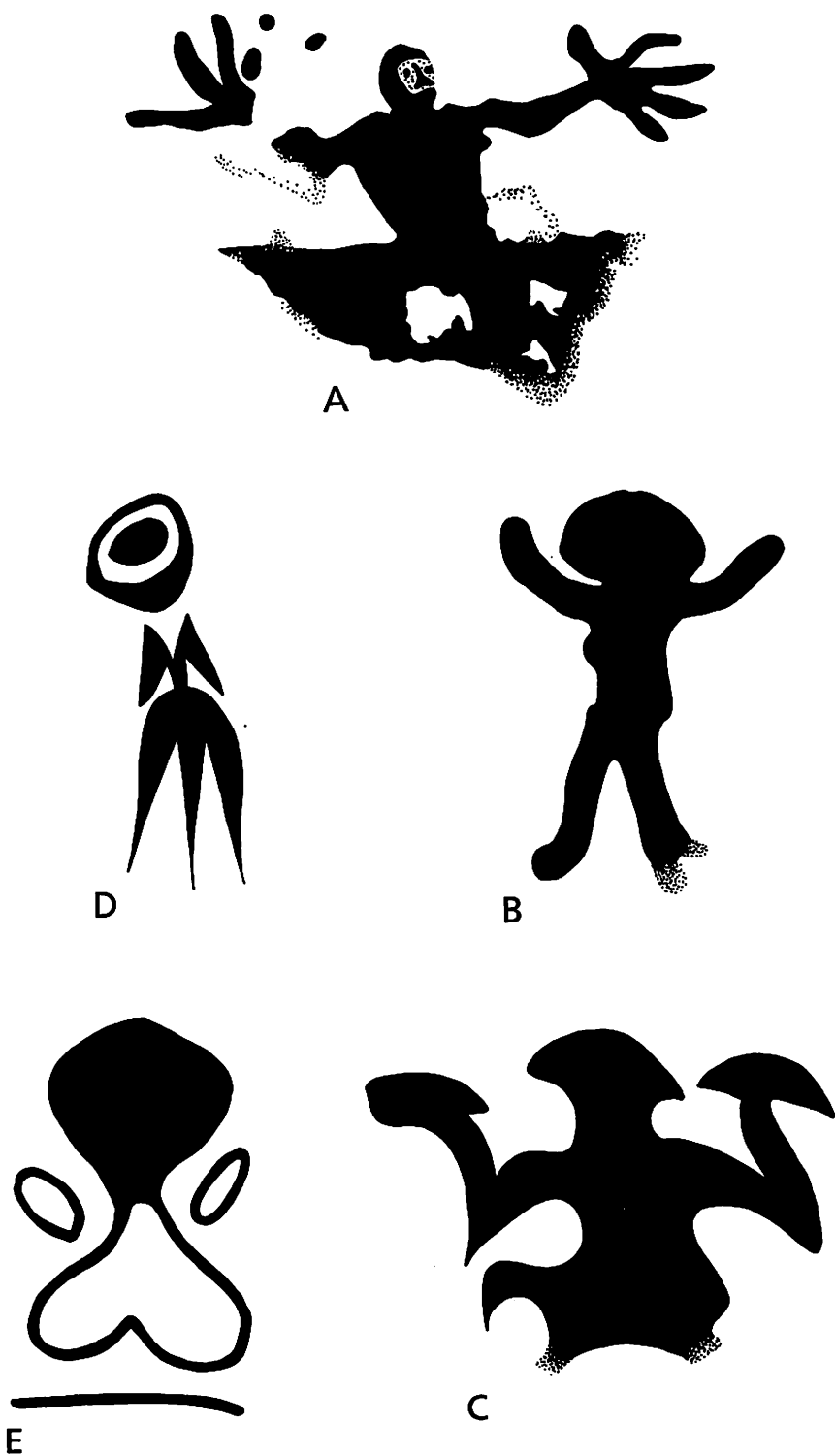

Fig. 27. Five examples of the treatment of the human figure in pictographs at Taberrakl and Olechuklars Along sites, Belau. Drawing after J. V.T. field data, 1987. Not to scale.

While there are some trait similarities between individual Belauan carvings and some Melanesian artwork there is not, in my opinion, a genuine and direct stylistic relationship between Melanesian iconographic traditions and Belauan stone sculpture style (either in the corpus as a whole or within type categories). Moreover, the peoples of Melanesia (New Guinea and Island Melanesia) are "markedly heterogeneous in languages, customs and biology" (Green 1989:207, citing Terrell). The areas in Island Melanesia that yield promise for iconographic comparison with Belau are precisely those which have an underlying Austronesian cultural component in the form of a Lapita presence (ibid.:208, fig.1; Newton 1988:10–23; Kaeppler 1976:198 makes this point with regard to dance traditions).

The megalithic traditions of Southeast Asia vary greatly in scope, style and scale. Beyer (1948) presents a broad survey of the Southeast Asia megalithic question in general and Heine-Geldern (1928) produced a fundamental investigation into function and meaning. Their early concept of a common origin and unified beliefs of a postulated "megalithic culture complex" has been abandoned or not emphasized by later researchers (cf. Schmitz 1961:234–49).

Fraser (1962:128–29) believes that the outstanding characteristic of the megalithic figures found in Asia-Oceania is aggressiveness. He suggests that, while the megalithic cultures were highly dynamic, the art was extremely static. The Belauan sculpture tradition described in this paper does not support the generalization of "static."

A survey of the literature for the Southeast Asian region illustrates an ample and rich descriptive data base, although few comparative analyses have been accomplished. The scope of megalithic construction, for instance, is suggested in west Sumba where "huge limestone boulders, weighing from ten to thirty tons, [were] lifted onto a wooden platform called a 'ship' (*tenda*) and dragged with vines to a hilltop village" (Nooy-Palm 1988:fig. 145). Bellwood (1985:150) has discussed the "massive chiefs' houses and the unique megalithic monuments of Nias," saying that "chiefly status for the living and the dead was the motivation behind the creation of the spectacular stone structures."

Female stone sculptures are known from the Lesser Sunda Islands, west Sumba. One figure is carved with breasts and was meant to be set into the ground at an altar where "prayers and offerings are made to ancestral and other spirits" (Barbier & Newton 1988:286, pl. 47). Statues with bisexual features are also known, and one interpretation of such figures is an increase of protective magic (Kleiweg de Zwaan 1922:342–46).

Interestingly, in Rindi, on the east coast, "a 'masculine' wood post stands vertically by a 'feminine' stone slab. This is an instance of the common eastern Indonesian concern with complimentary pairs which form a totality" (Barbier & Newton 1988:286, citing Forth 1981:118; see also Harrisson 1962; Parmentier 1987:169, n.25). Such a concern with "complimentary pairs" is seen in Belau at Ngkeklau (B:NA–1:1), Ngimis (B:NT–2:1) and Nglabang (B:NM–3:2) villages and perhaps in the multiple-faced images in Ngardmau (B:NR–2:1) and Irrai (Airai) (B:IR–1:1) states.

Also in the Lesser Sunda Islands at Atauro (a small island north of Timor) are found large (2 m tall) carved wooden ancestor figures. While not stone and of a style of unknown antiquity, the figures are interesting in that they wear on their heads a small, round form said to represent an "unripe coconut, an important component of rites concerning human fertility and childbirth" (Barbier & Newton 1988:296). The figures also commonly have a miniature male figure carved on the lower part of the post that, in some cases, "holds his erect phallus" (ibid.; see also Tobi stone portable figure posture, Black et al. 1979:349–53). This concept of the double male image on 1 (post) form may echo an older idea suggested in some of the Belauan Type A sculpture.

Loffler (1966) has discussed the religious and social symbolism of the sacrificial pole in the tribal populations of Southeast Asia. The phallic nature of the pole as symbol and the similar

significance of the forked post have also been described in relation to ancestor cults (cf. Horsky 1943:374–98).

Cumulative evidence suggests that the Belauan monoliths express conceptual or philosophical principles and human concerns shared with the larger Austronesian area. Within the sculpture corpus described here, indicators of the principles of dualism and spiritual transformation as well as concerns with fecundity and hierarchical relationships are (1) the depiction of both male and female as well as sexually ambiguous images, (2) paired or grouped placement, (3) representation of either a single being or multiple aspects of a single being on one form, (4) representation of both anthropomorphic and zoomorphic attributes on the same form, (5) ethnographic identification of sculpture with gods, ancestral spirits and/or sociopolitical groups (villages or clubs), and (6) size range.

CHRONOLOGY, PLACEMENT AND FUNCTION

Not 1 of the Belauan sculptures described in this paper can be directly dated, and none have been reliably dated through association. Both Hidikata (1973b) and Osborne (1966, 1979) suggested the probable antiquity of Type A sculpture, but the stylistic division is not necessarily simply “megalithic” and “post megalithic.” The types are not completely disassociated from one another in stylistic traits. Neither is there a discrete, temporal association of statue carving with statue use.

Osborne (1979:240) felt that the lack of ethnographic evidence associated with Type A sculpture indicated their antiquity. His chronological scheme suggested megalithic activity (including Type A sculpture) declining and probably ceasing by A.D. 1400.

Statues carved of andesite conglomerate (16 statues) are, in general, poorly preserved. The evidence on all sites is for differential weathering relative to location. All of the 18 Type A figures documented during this study are very heavily weathered (including Melekeok) and some are covered with moss. There is really nothing in their material condition as a group that can definitively contribute toward a specific temporal hypothesis without knowing more about site-specific rates of stone disintegration through controlled study.

The 6 documented Type B sculptures are in relatively good condition. This is due to the nature of the dense, hard volcanic breccia of which they were carved, the depth of the carving and their generally more sheltered locations. Even given this, however, a few are very softened in detail. The Types C (volcanic breccia) and D (coral “dripstone”) statues are more greatly worn, with the nature of the Type D carving material being the more susceptible to erosion.

Of the 9 statue location categories coded for 27 statues, the one most frequently noted was “directly related to *bai*” (10 statues plus 3 others directly upon a platform said to be a *bai*, or 48.1% of the total). The number of statues in this category would be substantially increased if the probable original location of the Melekeok sculptures had been coded.

The 2nd most frequently coded was “general village locus” (7 statues or 25.9% of the total, including Melekeok). The remainder were either isolated from architectural features (3 statues), related to paved or unpaved paths or trails (3 statues) or related to a terrace or field (1 statue).

Type A sculpture is found in nearly all location categories, with 9 of these statues being directly related to *bai* (including Bairulchau, considered here to be a *bai*) and 5 in a general village locus (including Melekeok). Three Type A sculptures are related to paved pathways or unpaved trails, and 1 is coded as directly related to a taro field, although a paved path is nearby. Both the locations and the scale of Type A statues suggest large group (public) significance.

The distributional data and stylistic evidence suggest an as yet undefined ideological relationship between Melekeok and Bairulchau. One might postulate the iconographic development of Type A sculpture from Ngarmid through Melekeok to Bairulchau, taking design from abstracted and integrated to realistic and distinct while continuing to employ the same basic

iconographic vocabulary. On the other hand, if Bairulchau should prove to be both an exceedingly early site as well as 1 of regional ideological and political importance, as the evidence to date clearly suggests, the implication would be the reverse. There is, however, a very clear and distinct stylistic relationship between all Type A sculpture, suggesting a developmental relationship as well.

Type B sculptures are in village locations on or related to stone platforms, some of which are *bai*. This is also true of Types C and D figures. The range of variation suggests individual and local innovation within an established iconographic tradition. The relationship of Type B statue design and detail to other Belauan artistic media (specifically, painted *bai* designs) tends to suggest a late temporal relationship in symbolism.

All but 2 of the total statue corpus documented are standing in erect positions, indicating continuing symbolic or even functional importance. This notion is supported by the ongoing ethnohistory. There is no obvious pattern in orientation of the head or face within the corpus, although an increased sample size may modify that opinion.

ETHNOGRAPHY AND MEANING

This paper considers taxonomy to be the first or “low-order meaning” based, in part, upon attribute (mode) distinction. Low-order meanings “provide the distinctions upon which those of higher order operate” (Rappaport 1979:126–28). In “higher-order meaning . . . similarities among obviously distinctive phenomena become more significant than the distinctions themselves” (*ibid.*:127). Metaphor provides a paradigm for higher-order meaning.

“Low-order meaning” is suggested here through the examination of sculpture attribute and in the taxonomy presented. For example, based on stylistic and context considerations alone it is possible to suggest that the Type A sculpture at Imul *bai*, Bairulchau and Melekeok might have been used by groups (clubs) or individuals (initiates) to commemorate success in warfare or the taking of trophy heads. Such warfare was “structured around a village system which, on Babeldaob Island, only dates back to the mid A.D. 1400’s,” or at the postulated end of the megalithic period (D. Snyder, pers. comm. 1990). These statues may also commemorate a high status lineage after which a club is named (frequently identified with a totem, cf. Force & Force 1972:53) or even a particular, legendary warrior. Mutilation of some sculptures may be evidence of objectified competition between such groups.

When we add ethnographic information to style and context data we find that the field of interpretation is greatly broadened. Name data recorded for the monoliths described here reveal that some statues have been designated by terms that are largely descriptive of current posture or conditions. Others are called by generic names that define categories such as “god of the village” or “guardian deity.” The term *chesuch* or “owl” is widely applied to Type A1 sculpture, and has been for some time. *Mengachui* is the name given 2 figures here and is ubiquitous throughout the Type B corpus. Some names denote sex (“Mr. Protection”) and 2 are connected with the usurper god *Medechiibelau*.

The interpretation of Type A sculpture as an aggressive symbol is supported somewhat by Kramer (1917–29:154–55), who describes and illustrates painted *bai* designs of anthropomorphic figures in profile with bird beaks, huge round eyes and tails between their legs to form erect penises (Fig. 28). The creatures were described as man eating devils (*tekiel malap*) who dwelt in the mountain forests, and 1 aspect of the story associates them with Imul *bai*. The story is long and involved with many asides, but the main points are that the *tekiel malap* were terrifying. They pursued, killed and ate “souls” at night dressed in “owl hats” so they wouldn’t be recognized, and they could be pacified with cooked food (specifically with coconut, see also Hidikata 1973b:23).¹²

12. Kramer (n.d. [HRAF]) describes “little demons, the relatives of the village god” who were said to “roam around”

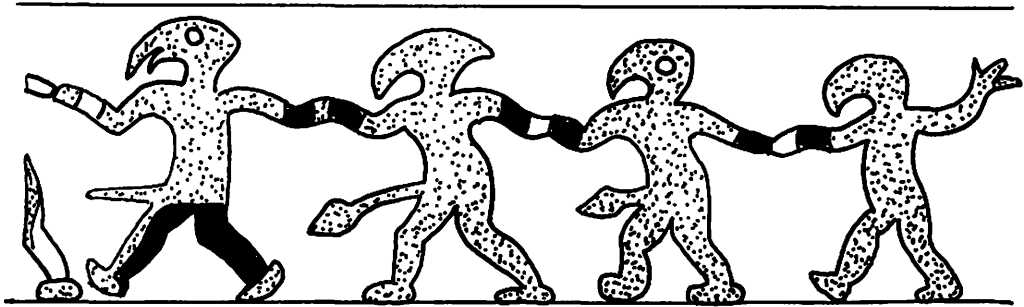

Fig. 28. "Eulenkopfen" or owl headed (masked?) anthropomorphs depicted in painted *bai* designs. After Kramer (1917-29:154-55).

The round and emphasized eyes, when coupled with the designation "owls" tends to link the secret, militant *tekiel malap* with Type A sculpture. Further, there is a very direct and valid iconographic connection between the arrow-shaped tails/penises of these *tekiel malap* and the form of the nose and eyes as 1 unified design motif on some Type B sculpture. There is also a similarly direct connection between the form of the spears carried by the *tekiel malap*, the shape of the tail/penis and the lizard symbol (Fig. 24; see also Kramer's doppeltafeln 1, 2, 4-7, 9, 10, 12, 13, 16, 18-20).

A related piece of ethnographic evidence is that "Von Miklucho-Maclay says that the stone *chelid* Olekeok receives sacrifices, and that it rises from the earth when club people have captured a head, and that residents of the village don't know anything about it" (Parmentier n.d.:10, citing Kramer). Such evidence, coupled with placement data, tends to suggest the late association of sculpture with secret organizations.

The carving style employed and the design variety achieved within the relatively small Type A corpus suggests that the symbolism was dynamic and active and that carving was not always undertaken by well-taught and controlled experts (cf. Osborne 1979:269-70). Indeed, it is possible that some may have been produced by organized group efforts (especially in Melekeok).

I am drawn to the formation of a hypothesis that suggests that the Type A "quadrapped" symbol at the Ngarmid and *Tmud* sites might have meanings associated with women/procreation/childbirth (as does the Ngiwal shell mask [Hidikata 1973a:82-83]). It is tempting to suggest that the "quadrapped" as seen on those sites might represent an essentially passive and benign aspect of the same symbol depicted as fierce and aggressive on Type A figures at Melekeok and Bairulchau. The irritable child biting its mother's nipples may be a metaphor for aggression or warfare (Hidikata 1973b:70 reports folktale). Depiction of feminine/masculine qualities in balance is part of the richness of fertility imagery in Oceanic societies. The goddess/nursing mother fertility symbolism may be further, more abstractly signaled by secondary

a village *bai* and were sufficiently frightening that the chiefs would not sleep in the *bai*. Another story (Kramer 1917-29:III, 207-210) tells of a stone that represents the "greedy devil" who extorted gifts from canoers. As he was pursued, the devil "turned himself into a stone."

Kesolei (1975:67) reports a story dealing with "*Tekii-melab* (spirits who ate human beings)" that were said to be sons of a local "spirit or goddess." They brought collected (extorted) food to the chief of Melekeok to support their sister (the chief's wife). They were, in turn, fed on roasted or fried coconuts (*uleouchi*), a sacred food and magical offering. The chief proceeded in a ceremonial canoe procession from Melekeok to Bairulchau, where a feast (*mur*) was held in honor of his wife and the *tekii-melab* acted as messengers. In the *Milad* story the *Tekilmelab* are described as "seven gods who went fishing for human catch" (Parmentier 1981:255, citing a recently recorded version of the story). The *Tekilmelab* are the 7 *chelid* of the heavens (Parmentier 1981:258, citing Kramer). My own opinion is that the 7 *chelid* as *Tekilmelab* may be incarnate in the Pleiades.

associations attached to the cylindrical shape on the tops of Type B statue heads. A continuity of meaning between Type A and some Type B sculptures thus appears to be inherent.

Within historic village areas a variety of carved and uncarved Types B, C and D monoliths were (and frequently still are) associated with ancestral spirits, chiefly leadership, regional gods, fertility/increase/sexuality or protective or threatening forces. These stones are frequently named and have often been moved from one village to another or one part of a village to another, where some may have functioned as geographic markers (Hidikata 1973b:83; see also Parmentier's [1981] "post," "path" and "sides" models). The antiquity of the names and histories of the stones is not well established in all cases, and there is an overlay of *Modekngei* associations (Hidikata 1973b:18). It does seem clear, however, that stones gain in prestige and value as they gain in attached oral history (cf. Hidikata 1973b:14, 18, 24). Further, their metaphoric qualities are extended in relation to their symbolic complexity.

The partial function of Types B, C and D sculpture, therefore, may be to condense clan or village history into an objectified form (there are frequent references to "listening" and "hearing news"). That function certainly evolved over time as the actual and ritual contexts of the sculptures frequently or repeatedly changed (see Hidikata 1973b, who also mentions probable evolution of statue purpose and function). I find it logical that these sculptures may have been regarded as tokens to be used in the payment of fines or tribute. As such, they may have a general functional and temporal relationship to Yap stone money.

The underlying stylistic unity of all Belauan stone monoliths is the carved "post" concept (cf. Hidikata 1973b:55–56 for discussion of "forked" or bifurcated stones, *bai* stone posts and monolith form). The 1st and most profound level of inherent meaning is the sacred tree, grove or "cosmic pillar" of Oceania.¹³ The impetus for sculptured posts is the sacred meetinghouse of tribal Austronesian societies (Bellwood 1985:151; Waterson 1988). The direct, metaphorical reference is to the sacred leader/god as "post" around whom the community is ordered (cf. Kramer 1917–29:IV, 207–10; McKnight 1970:5).¹⁴

It is important to realize that while both the symbolic form and the connotation of "post" is generally phallic, the specific leadership that it represents might be either a male or female person/god or male and female qualities in spiritual balance. The power inherent in leadership is on the male side of philosophical dualism, but in some societies (including Belau) such power could be actualized within women leaders.

The transformation of the wood post to stone is an aspect of meaning requiring more research. In Timor, all sacrificial posts of both wood and stone in anthropomorphic form are called "*ai tos*" or wood/hard, indicating that all such posts may originally have been wood (Hicks 1988:141, fig. 147). Stone posts utilized on a truly megalithic scale in Micronesia are best seen in the *latte* concept. This adaptation in material was facilitated by the availability of good quality material and the more permanent nature of stone. It would also certainly have

13. Lessa (1966:12) describes the widespread mythological occurrence of the "cosmic pillar" concept. An "un-specified tree called *Sur Lang*, or Pillar of the Sky" in Ulithi is suggested by informants to have been "made of stone, rising upwards out of a distant place in the sea." In another Ulithi tale that is of probable Yap origin, men use bamboo to "climb to the Sky World." Lessa (*ibid.*) is of the opinion that "the exact nature of the pillar is unimportant," it is the journey upwards that is significant.

Parmentier (1987:132, n.5) describes the semantic range of terms related to Belauan *uchul*, the extended meaning of which "appears to be 'tree trunk.'" His preferred meaning of "the quest to climb to the heavens" is as a "quest for land based existence" rather than reunification, rebirth or transcendence.

14. The ethnographic association of sacred stones in Belau with specific beings (human or animal) and spirits/gods of both sexes is widely known (Force & Force 1972:106, n.15). Many legends specifically tell of humans and gods turned to stone. The "god *Jegadrengei* created the sun and the moon, and he still stands there in stone" (Kramer n.d. [HRAF:197]). "Near the *Rubakbai* there is a pile of stones, the grave of *Malsol*, whose corpse was turned into stone here" (*ibid.*:210). Indeed, the metaphor for the configuration of Belau itself is the body of a fallen giant.

had a philosophical rationale. In Belau, sculptural material such as clam shell may have been selected for associative meanings (the role of the giant clam in creation tales, for example). Red scoriaceous material was also utilized for uprights not carved as human faces.

Oceanic "post" sculptures occur in a variety of forms and sizes (cs. Cox & Davenport 1988). For example, some were carried in the hands of chiefs and priests. These and other, larger ones were capable of being stuck in the ground. The erection of some of the largest posts/images had distinct procreative/fertility values. Multiple (repeated) anthropomorphic images were carved on some types of posts or sticks and allude to conceptual and ritual repetition.

One of the most fascinating aspects of meaning is the variable context of carved posts in interior and exterior space. Interior context allows private and circumscribed access to meaning. Exterior context provides public access to image but meaning may still only be partially attainable. Exterior (public) context is a significant aspect of Belauan monolithic sculpture, even when scale varies across type.

Formal and symbolic continuity evidenced in all of the Belauan sculpture types described here has produced a distinctive sculptural style describing a genuine Belauan tradition. Components of Belauan style include (1) major emphasis on the head, although depiction of the torso is known, (2) inherent bilateral symmetry, (3) manipulation of the eyes/nose as a phallic motif, (4) manipulation of the "quadraped" symbol to create the double face motif, (5) selection of the eyes as an attribute for sculptural emphasis,¹⁵ (6) closed, compact treatment of form, (7) integration of zoomorphic and anthropomorphic symbols, (8) subtle incorporation of non-overt sexual symbolism, (9) expression of feminine and masculine qualities on 1 form, and (10) highly skillful employment of relief techniques and manipulation of facial expression. Facial expressions may represent qualities that they straightforwardly appear to be (i.e., defiance, anger, contempt, bemusement).¹⁶

Typological analysis reveals definite developmental stages of Type A iconography. The direction of these changes, whether from abstract (Ngarmid) to realistic (Bairulchau) or the reverse, requires better dates from both sites. An associated date for any 1 of the Type A statues or the addition of a dated figure to the corpus would clarify the question for the entire type category. At this stage of research and considering the cumulative archaeological and stylistic evidence, I consider the Bairulchau statues to be earlier than the other Type A figures.

The stylistic variety, coupled with the underlying symbolic unity, suggests a long but nonlinear development of Belauan sculpture style. Viewing anthropomorphic examples within the context of other types of "sacred stones," it is apparent that stonemasonry was a recognized vehicle for the objectification of Belauan philosophical concepts for many centuries.

A key attribute variant that distinguishes Types B, C and D sculpture from Type A is decreased emphasis on megalithic presence. A 2nd is increased detail work and the associated increase in time/skill/resource investment. An important social variable is the implied involvement of somewhat large groups in the carving, transport and erecting of Type A sculpture. It is clear, however, that the relatively simple and local quarrying and transport involved in Type A sculpture did not require massive manpower (cf. Heizer 1966:825, figs. 6, 7).

15. There is, throughout Oceania, an association of human eyes with the stars and gods. Belauan gods "look down at night with their sparkling eyes" (Parmentier 1981:259, citing early data recorded by Semper 1982). Hidikata (1973b:83) notes the significance of the eyes as an iconographic symbol on the Ngiwal shell mask, and Parmentier (1981:248-49) describes some of the associated meanings of *mad* (eye).

16. An association of human personality traits and facial expressions with places (villages) may exist. "The Imiungs look," a "haughty or severe countenance" is described for the people of Imeong, while connotations of "openly boastful" or "stubborn" are given for those from Melekeok (Parmentier 1981:264). Masculine and feminine qualities may be similarly assigned.

CONCLUSION

In my opinion, the Belauan sculptural tradition is an integrated expression of local artistic concepts demonstrating formal and symbolic continuity as well as transformation over time. Belauan style has been described and possible differential function suggested through analysis of placement and context. The classification scheme suggested here is chronologically sensitive but not, at this stage of research, chronologically based.

Stylistic and iconographic relationships between Belauan monolithic sculpture, *bai* designs and pictographic motives definitely exist. These relationships are expressed in the design of anthropomorphic figures, and many elements of Belauan sculpture style apply to both *bai* and rock art designs.

While there are clearly enough descriptive data presented here to define Belauan stone sculpture style and facilitate continued comparative analysis, without chronological control the developmental direction of that style can only be hypothesized. One suggested interpretive direction for Type A figures requires further elucidation of Kramer's (1917-29:154-55) data on the *tekiel malap*.¹⁷

Belauan sculpture is not clearly linked with a specific extraisland corpus as directly antecedent. Continued comparative analysis requires a larger sample, but would most profitably focus upon those Austronesian cultures of Island Southeast Asia that possess megalithic remains, with special emphasis on the areas of Lombok, Nias and Timor. In Micronesia, the genre figures most comparable to Types B and C are the typhoon masks of the Mortlock Islands. Underlying symbolic echoes of meaning that resonate with the styles of eastern Melanesia are due, in part, to the pervasive effect of Lapita style in Oceanic arts (cf. Newton 1988:15, 23).

ACKNOWLEDGMENTS

As always, field work of the type described in this paper owes a great deal to many people. While I wish to acknowledge this debt, I hasten to point out that the research presented here, with all of its errors and omissions, is my own responsibility.

I am grateful to Mr. Moses Sam, director of the Division of Cultural Affairs, Oreor, for permission to do field work in Belau and to Dr. Douglas Osborne and Dr. George Gumerman, who supported my request. Mr. Vince Blaiyok of the Division generously provided assistance with site records and in the field at Ngardmau.

My field work would have been virtually impossible without the generous use of boat transport provided by Mr. Dorotea Nagate, executive director of the Palau Community Action Agency (PCAA). Special thanks are due to Bismarck Brel and the Agency's experienced boatmen, who saw us safely through Belau's challenging waters. At the rock art sites we were graciously aided by Mandy Thyssen and Shallum Etpison, who found the Mecherchar Island rock art site.

At the Belau Museum, Director Olympia Morei, Kempis Mad and Simeon Adelbai assisted with photographic collections and ethnographic materials. Marty Gonzalez and her students in the Belau High School summer program were a welcome and enriching component of the field work and did very useful ethnographic work, especially at Melekeok and Imeong where they were assisted by Kempis Mad. Among the most steadfast and helpful were Xavier Ridep, Eileen Mad, Antoinette Issac and Eunice Reidinch.

All of the Belau research team have worked with me previously on Easter Island and on numerous

17. On *Rapa Nui* (Easter Island), the *manu tara* (birdman) cult employed carved stone to depict the birdman, frequently on monolithic statues or sites (Van Tilburg & Lee 1987). A terroristic element that may have been a secret, masked society evolved and behaved in similar ways to the *tekiel malap* (cf. Metraux 1940; Teilhet 1979). Anthropomorphic sculpture associated with stone shrines on Necker Island may relate to cult activities centered upon the massive bird colonies on the island (P. Cleghorn, pers. comm. 1984, 1988:48).

other special projects. Photography was accomplished by David C. Ochsner with Marieka Van Tilburg as assistant. Valerie De Gier did German language research and, with her daughters, assisted at Bairulchau and Ngetpang. Gordon Hull did valuable map and photo research. Finished drawings are by Curtiss H. Johnson. Johannes Van Tilburg assisted in the field and with the development of graphics. The collective energy and expertise of all of these talented people is gratefully acknowledged.

Special thanks to Dr. Dirk Ballendorf for his hospitality and help with the Belauan language; Dr. James Carucci, who provided information on the Imul site; Dr. David Snyder, who provided site numbers and shared his thoughts on Belau archaeology in general; Dr. Bruce G. Karolle, who provided the map of Belau and corrected place names; Dr. Richard Parmentier, who generously provided his unpublished notes on "sacred stones" and commented on this paper in draft, and most especially to Dr. Douglas and Mrs. Carolyn Osborne. Both kindly shared their library and patiently listened to my ideas, answered my questions, read and reviewed my work. My research was facilitated by the dedication and high professional standards that they bring to archaeology. Faye Sotirakis was an able and patient editor. Lynn Lockie and Kyle Odermatt assisted in the preparation of the manuscript.

The field work was funded by a grant from School of the Pacific Islands, Inc. I am grateful to Mr. Larry Janss, Ms. Nancy Goglia and Ms. Nancy Burke. Most importantly, I wish to thank the kind and generous people of Belau, who welcomed us into their villages, their homes and their lives, however briefly.

APPENDIX

The following is a partial list of anthropomorphic figures from Belau held in the collection of the Bernice P. Bishop Museum, Honolulu, Hawai'i. The figures are listed here because each has some interesting feature or detail. These pieces and a variety of other materials, including carved wooden story boards (a modern art form), painted "plaques," and 5 interesting samples of red, black and yellow pigments were examined in March 1987. The pigments were used for various specialized purposes, including face and body paint.

My general goal was to gain an overview of Belauan artistic conventions employed in several media and over a range of time to depict the human form. The time I had to do this research was unfortunately brief, and a great deal remains to be done in order to more fully elucidate Belauan sculpture style. I am indebted to the staff of the Museum for their courteous assistance with this work.

1. Stone "idol" from the Caroline Islands; roughly pecked from coralline rock; almost shapeless and in 2 pieces; no stylistic detail; no date; may be from Tobi (?). Identification number 7116.
2. Mask of a grotesque human face carved of coconut leaf butt; enhanced with red, white and black paint; collected in Koror in 1936 and considered to be "modern." Identification number C.8680, (St 9-D-2).
3. "Idol" carved of wood; approximately 15 in. tall; collected in Koror, no date. Identification number C. 9676, (33-10-E-2).
4. Carved wooden figures, 1 on the head of another; "Palau?" Identification number D. 1238, (St 10-B-1).
5. Cast of the "Ngiwal face"; no date, purpose unknown but probably made for exhibit; cast does not show inlaid eyes. Acc. no. 5366, (HM2-1-IB-C-1).
6. Several carved wooden images of the type popularly known as the "monkey man"; vary in quality; "modern." Identification number X-A-1 for reference.
7. Anthropomorphic image; no date. Identification number 1976.60.0.

LITERATURE CITED

- Aoyagi, M.** 1987. Gods of the Modekngel religion in Belau. In: I. Ushijima & K. Sudo, eds., Cultural uniformity and diversity in Micronesia. Senri Ethnological Series no. 21, p. 339-62. Osaka.
- Athens, J. S.** 1986. Nan Madol: Archaeology of a Pohnpeian chiefdom center. MS., OHP, Saipan.
- Ayres, W. S.** 1978. Micronesian prehistory: Research on Ponape, Eastern Caroline islands. In: V. N. Misra & P. Bellwood, eds., Recent advances in Indo-Pacific prehistory, p. 399-409. Oxford & IBH Publishing Co., New Delhi.

- Barbier, J. P. & D. Newton.** 1988. *Islands and ancestors: Indigenous styles of Southeast Asia*. Metropolitan Museum of Art, New York.
- Barnett, H. G.** 1949. *Palauan society: A study of contemporary native life in the Palau islands*. Univ. of Oregon, Eugene.
- Best, S.** 1988. Here be dragons. *J. Polynes. Soc.* 97(3):239–59.
- Bellwood, P.** 1979. *Man's conquest of the Pacific: The prehistory of Southeast Asia and Oceania*. Oxford Univ. Press, New York.
- . 1985. *Prehistory of the Indo-Malaysian Archipelago*. Academic Press, New York.
- Beyer, H. O.** 1948. Philippine & East Asian archaeology, and its relation to the origin of the Pacific islands population. *National Research Council of the Philippines, Bull.* 29:1–130.
- Black, P., D. Osborne & M. Patricio.** 1979. Tobi Island artifacts. *Micronesica*, Supplement 1, p. 349–53.
- Blust, R. A.** 1976. Austronesian culture history: Some linguistic inferences and their relations to the archaeological record. *World Archaeol.* 8:19–43.
- Bulmer, R. & S. Bulmer.** 1962. Figurines and other stones of power among the Kyaka of central New Guinea. *J. Polynes. Soc.* 71(2):192–209.
- Butler, B.** 1983. A preliminary report on the 1983 archaeological survey of Aimeliik State, Republic of Palau. MS. Center for Archaeological Investigations, Southern Illinois Univ., Carbondale.
- Campbell, K. S.** 1971. *The stone sculpture of the Pacific islands: A compilation and stylistic comparison*. M.A. thesis, Univ. of Hawaii.
- Carucci, J.** 1984. Archaeological survey of the Bai ra-Irrai, Airai State, Republic of Palau. MS. 1984–14, Center for Archaeological Investigation, Southern Illinois Univ., Carbondale.
- Chapman, P. S.** 1968. Japanese contributions to Micronesian archaeology and material culture. In: I. Yawata & Y. H. Sinoto, eds., *Prehistoric culture in Oceania: A symposium*, p. 67–82. Bishop Museum Press, Honolulu.
- Christian, F. W.** 1899. *The Caroline Islands: Travel in the sea of little lands*. Methuen & Co., London.
- Cleghorn, P. L.** 1988. The settlement and abandonment of two Hawaiian outposts: Nihoa and Necker islands. *Occas. Pap.* 28:35–49. Bernice P. Bishop Museum, Honolulu.
- Cox, J. H. & W. H. Davenport.** 1988. *Hawaiian sculpture: Revised edition*. Univ. of Hawaii Press, Honolulu.
- Force, R.** 1960. Leadership and cultural change in Palau. *Fieldiana: Anthropology*, vol. 50. Chicago Natural History Museum, Chicago.
- Force, R. & M. Force.** 1972. Just one house: A description and analysis of kinship in the Palau Islands. *Bernice P. Bishop Mus. Bull.* 235. Bishop Museum Press, Honolulu.
- Forth, G. R.** 1981. *Rindi*. Nijhoff Press, The Hague.
- Fraser, D.** 1962. *Primitive art*. Thames and Hudson, London.
- Fujimura, K. & W. Alkire.** 1977. Recent excavations on three atolls in the Caroline Islands: A note. *J. Polynes. Soc.* 86:413–14.
- Goodenough, W.** 1955. A problem in Malayo-Polynesian social organization. *Am. Anthropologist* 57:71–83.
- Green, R. C.** 1989. Lapita people: An introductory context for skeletal materials associated with pottery of this cultural complex. *Rec. Australia Mus.* 41(3):207–13.
- Gumerman, G. J., D. Snyder, & W. B. Masse.** 1981. An archaeological reconnaissance in the Palau Archipelago, Western Caroline Islands, Micronesia. Center for Archaeological Investigations Res. Pap. 23. Southern Illinois Univ., Carbondale.
- Harrison, T.** 1958. A living megalithic in upland Borneo. *Sarawak Mus. J.* 8(12):694–702.
- . 1962. Megaliths of Central Borneo & Western Malaya, compared. *Sarawak Mus. J.* 10(19–20): 376–82.
- . 1970. The puzzling “Waisted Stones”: From Borneo to Easter Island? *Sarawak Mus. J.* 28(36–37):70–90.
- Heine-Geldern, R.** 1928. Die megalithen sudostasiens und ihre bedeutung furdie megalithenfrage in Europa und Polynesien. *Anthropos* 23:276–315.
- Heizer, R. F.** 1966. Ancient heavy transport, methods and achievements. *Science* 153(3738):821–30.

- Hicks, D.** 1988. Art and religion on Timor. In: J. P. Barbier & D. Newton, eds., *Islands and ancestors: Indigenous styles of Southeast Asia*, p.138–51. Metropolitan Museum of Art, New York.
- Hijikata [Hidikata], H.** 1956. Report on consecrated stone images and other stone works in Palau, Micronesia. Tokyo.
- . 1973a. Palauan kinship. Micronesian Area Research Center Pub. no. 1. Garrison and McCarter, Agana, Guam.
- . 1973b. Stone images of Palau. Micronesia Area Research Center Pub. no. 3. Garrison and McCarter, Agana, Guam.
- Hockin, J. P.** 1803. A supplement to the account of the Pelew Islands. G. and W. Nicol Press, London.
- Horsky, R.** 1943. Religiöse Holzplastik auf Nias. *Annales des Naturhistorischen Museums in Wien* 53(1):374–98.
- Hoskins, J.** 1988. Arts & cultures of Sumba. In: J. P. Barbier & D. Newton, eds., *Islands and ancestors: Indigenous styles of Southeast Asia*, p. 120–37. Metropolitan Museum of Art, New York.
- Howells, W. W.** 1973. *The Pacific Islanders*. Scribner's, New York.
- Jensen, A. E.** 1960. Feld-Terrassen und megalithen. Eine Skizze. *Paideuma* 7(4–6):258–73.
- Kaeppler, A. L.** 1976. Dance and interpretation of Pacific traditional literature. In: A. L. Kaeppler & H. A. Nimmo, eds., *Directions in Pacific traditional literature: Essays in honor of Katharine Luomala*, p. 195–216. Bishop Museum Press, Honolulu.
- Karolle, B. G.** 1987. *Atlas of Micronesia*. Guam Publications, Inc., Agana, Guam.
- Karolle, B. G. & D. Antonelli.** 1985. Geographical knowledge in American Micronesia. *Illinois Geog. Soc. Bull.* 28(2):28–34. Illinois State Univ., Normal.
- Keate, G.** 1788. An account of the Pelew Islands . . . from the journals and communications of Captain Henry Wilson, 1783. G. Nichol, London.
- Kesolei, K., ed.** 1975. Palauan legends, no. 2. Palau Community Action Agency, Koror.
- Kleinweg de Zwaan, J. P.** 1922. Deux singuliers fetiches de l'île Nias. *Revue Anthropologique* 9–10:342–46.
- Kramer, A.** n.d. Palau. Partial translation, HRAF.
- . 1917–29. Palau. 5 vols. In: G. Thilenius, ed., *Ergebnisse der Sudsee-Expedition, 1908–1910*. Hamburg.
- Kurashina, H., D. Moore, O. Kataoka, R. C. Shulte & E. Ray.** 1981. Prehistoric and protohistoric cultural occurrence at Tarague, Guam. *Asian Persp.* 24:57–68. Univ. of Hawaii Press, Honolulu.
- Labang, L.** 1962. "Married Megaliths" in Upland Kalimantan. *Sarawak Mus. J.* 10(19–20):383–85.
- Lee, G.** 1986. Easter Island rock art: Ideological symbols and socio-political change. Ph.D. dissertation, UCLA.
- Leone, M.** 1982. Some opinions about recovering mind. *Am. Antiquity* 47:742–60.
- Leigh-Theisen, H.** 1985. *Der sudostasiatische archipel: Volker und kulturen*. Museum Fur Volkerkunde, Vienna.
- Lessa, W. A.** 1975. Drake's island of thieves: Ethnological sleuthing. Univ. of Hawaii Press, Honolulu.
- Linton, R. & P. S. Wingert.** 1946. *Arts of the South Seas*. The Museum of Modern Art, New York.
- Loffler, L. G.** 1966. Beast, bird and fish: The sacrificial pole as a cosmological centre. *Abstracts of Papers Related with social sciences and anthropology*. Proceedings of the Eleventh Pacific Science Congress, vol. IX, Symposium no. 49. Tokyo.
- Lucking, L. J.** 1984. An archaeological investigation of prehistoric Palauan terraces. Ph.D. Thesis, Univ. of Minnesota.
- Masse, W. B., D. Snyder & G. J. Gumerman.** 1984. Prehistoric and historical settlement in the Palau Islands, Micronesia. *New Zealand J. Archaeol.* 6:107–127.
- McKnight, R. K.** 1970. Orachl's drawings: Palauan rock paintings. *Micronesian Res. Working Pap.* no. 1. Trust Territory of the Pacific Islands, Saipan.
- McManus, E. G.** 1976. *Palauan-English dictionary*, L. S. Josephs, ed. Univ. of Hawaii Press, Honolulu.
- Metraux, A.** 1940. *Ethnology of Easter Island*. Bull. 160. Bernice P. Bishop Museum, Honolulu.
- Meyn, S. L.** 1982. *Black island paradise: Life in Melanesia*. Cincinnati Museum of Natural History, Cincinnati.
- Miller, D.** 1985. *Artefacts as categories: A study of ceramic variability in Central India*. Cambridge Univ. Press, Cambridge.

- Montvel-Cohen, M.** 1987. Continuity and change in the material culture of Micronesia. Isla Center for the Arts, Agana, Guam.
- Morgan, W. N.** 1988. Prehistoric architecture in Micronesia. Univ. of Texas Press, Austin.
- Newton, D.** 1971. Crocodile and cassawary: Religious art of the Upper Sepik river, New Guinea. The Museum of Primitive Art, New York.
- . 1979. Prehistoric and recent art styles in Papua New Guinea. In: S. M. Mead, ed., *Exploring the visual art of Oceania: Australia, Melanesia, Micronesia, and Polynesia*, p. 32–57.
- . 1988. Reflections in Bronze: Lapita & DongSon art in the Western Pacific. In: J. P. Barbier & D. Newton, eds., *Islands and ancestors: Indigenous styles of Southeast Asia*, p. 10–13. Metropolitan Museum of Art, New York.
- Nooy-Palm, C.H.M.** 1988. The Mamasa and Sa'Dan Toraja of Sulawesi. In: J. P. Barbier & D. Newton, eds., *Islands and ancestors: Indigenous styles of Southeast Asia*, p. 86–106. Metropolitan Museum of Art, New York.
- Osborne, D.** 1966. The Archaeology of the Palau Islands: An intensive survey. Bernice P. Bishop Mus. Bull. no. 230. Bishop Museum Press, Honolulu.
- . 1979. Archaeological test excavations, Palau Islands, 1968–1969. *Micronesica*, Supplement 1.
- Osborne, D. & L. Gregory.** 1979. The Aulong 4 pictographs. In: D. Osborne, *Archaeological test excavations, Palau islands, 1968–1969. Micronesica*, Supplement 1.
- Palau Register of Historic Places Manual for Numbering System.** 1980. Palau Historical and Cultural Preservation Commission.
- Parmentier, R. J.** 1981. The sacred remains: An historical ethnography of Ngeremlengui, Palau. Ph.D. dissertation, Univ. of Chicago.
- . 1987. The sacred remains: Myth, history, and polity in Belau. Univ. of Chicago Press, Chicago.
- . 1988. Transactional symbolism in Belauan mortuary rites: A diachronic study. *J. Polynes. Soc.* 97(3):281–312.
- . n.d. [1989]. Working inventory of stones in Belau. MS.
- Peacock, D. J.** 1987. Lee Boo of Belau: A prince in London. Univ. of Hawaii Press, Honolulu.
- Rappaport, R. A.** 1979. Ecology, meaning and religion. North Atlantic Books, Berkeley.
- Reinman, F.** 1968. Radiocarbon dates from Guam, Marianas Islands. *J. Polynes. Soc.* 77(1):80–82.
- Riebe, I.** 1967. Anthropomorphic stone carvings on Unea Island. *J. Polynes. Soc.* 76:374–78.
- Schmitz, C. A.** 1961. Gibt es eine 'Megalith-Kultur' in Ozeanien? *Zeitschrift für Ethnologie* 86:234–49.
- Schneebaum, T.** 1985. Asmat images: From the collection of the Asmat museum of culture and progress. Asmat Museum of Culture and Progress, Irian Jaya.
- Semper, K.** 1982. The Palau Islands in the Pacific ocean. Mark L. Berg, trans.; Robert D. Craig, ed. *Micronesian Area Research Center*, Univ. of Guam.
- Shutler, R., Jr. & J. C. Marck.** 1975. On the dispersal of the Austronesian horticulturalists. *Archaeology and Physical Anthropology in Oceania* 10:81–113.
- Shutler, R., Jr. & M. E. Shutler.** 1975. *Oceanic Prehistory*. Cummings Publishing Co., Menlo Park, Calif.
- Skinner, H. D.** 1964. Crocodile and lizard in New Zealand: Myth and material culture. Records of the Otago Museum, no. 1. Dunedin.
- Spoehr, A.** 1957. Marianas prehistory: Archaeological survey and excavations on Saipan, Tinian and Rota. *Fieldiana: Anthropology*, vol. 48. Chicago Museum of Natural History, Chicago.
- Smith, C. W.** 1983. Survey of islands of Palau, Republic of Palau. U.S. Department of Agriculture Soil Conservation Service.
- Snyder, D.** 1983. Archaeological surveys in Ngardmau and Ngchesar, Republic of Palau. Center for Archaeological Investigation, Southern Illinois Univ., Carbondale.
- . 1985. An archaeological survey of Koror State, Republic of Palau. MS file 1985–13. Center for Archaeological Investigation, Southern Illinois Univ., Carbondale.
- Strack, R., ed.** 1990. Center for Archaeological Investigations Newsletter. Southern Illinois Univ., Carbondale.
- Takayama, J.** 1981. Early pottery and population movements in Micronesian prehistory. *Asian Persp.* 24:1–10.
- . 1982. A brief report on archaeological investigations of the southern part of Yap Island and nearby

- Ngulu Atoll. In: M. Aoyagi, ed., *Islanders and their outside world: A report of the cultural anthropological research in the Caroline Islands of Micronesia in 1980-1981*, p. 77-104. Rikkyo Univ., Tokyo.
- Takayama, J. & T. Egami.** 1971. *Archaeology on Rota in the Mariana Islands*. Reports of Pacific Archaeological Survey, no. 1. Tokai Univ., Hiratsuka City.
- Teilhet, J. H.** 1979. The equivocal nature of a masking tradition in Polynesia. In: S. M. Mead, ed., *Exploring the visual art of Oceania: Australia, Melanesia, Micronesia and Polynesia*, p. 192-201. Univ. of Hawaii Press, Honolulu.
- Van Tilburg, J.** 1986. *Power and symbol: The stylistic analysis of Easter Island monolithic sculpture*. Ph.D. dissertation, UCLA.
- . n.d. [1987]. *A preliminary typology of monolithic stone sculpture in archaeological contexts, Republic of Belau (Palau), Micronesia*. MS.
- . 1987. *Larger than life: The form and function of Easter Island sculpture*. *Musées Royaux D'Art et D'Histoire Bulletin* 58(1):111-30. Brussels.
- . 1988. *Easter Island statue type. Part three: The Moai as ideological symbol*. In: C. Cristino F. et al., eds., *Archaeology 1:164-73*. First International Congress Easter Island and East Polynesia, Hanga Roa, Easter Island, 1984. Universidad de Chile, Santiago.
- . 1989. *The klidm of Belau. Guam and Micronesia Glimpses*, p. 45-52.
- Van Tilburg, J. & G. Lee.** 1987. *Symbolic stratigraphy: Rock art and the monolithic statues of Easter Island*. *World Archaeology* 19(2):133-49.
- Waterson, R.** 1988. *The house and the world: The symbolism of Sa'Dan Toraja house carvings*. *Res* 15, p. 35-61.
- Whallon, R. & J. A. Brown, eds.** 1982. *Essays on archaeological typology*. Center for American Archaeology Press, Evanston, Ill.
- Wood, J. G.** 1860. *The natural history of man: An account of the manners & customs of the uncivilized races of men*. Home Book Co., New York.
- Wycherly, G.** 1928. *Buccaneers of the Pacific*. Bobbs-Merrill, Co., Indianapolis.